



RK3588 EVB

User Guide

Releaseversion:V1.0

Releasedate:2022-1-25

Disclaimer

This document is provided "status quo", Rockchip Electronics Co., Ltd. ("the company", the same below) does not make any statements, information and content of this document on the accuracy, reliability, completeness, marketability, or specific purpose and non-infringement provide any express or implied statement or guarantee. This document is only used as a reference for instructions.

Due to product version upgrades or other reasons, this document will be updated aperiodic. Unless otherwise agreed, this document is only used as a guide. All statements, information and suggestions in this document do not constitute any express or implied warranty.

Brand Statement

"Rockchip" and "瑞芯微", "瑞芯" and other Rockchip trademarks are trademarks of Rockchip Electronics co., ltd., are exclusively owned by Rockchip Electronics Co., Ltd.

All other trademarks or registered trademarks mentioned in this document are owned by their respective owners.

Copyright © 2022 Rockchip Electronics Co., Ltd.

Without the written permission of the company, any unit or individual shall not extract or copy part or all of the content of this document, shall not disseminate it in any form.

Rockchip Electronics Co., Ltd.

Add: No.18 Building, A District, No.89, software Boulevard Fuzhou, Fujian, PRC

Web: www.rock-chips.com

Hotline: +86-591-83991906

Fax: +86-591-83951833

Email: fae@rock-chips.com



Preface

Overview

This guide mainly introduces the basic functions and hardware features, multi-function hardware configuration, and software debugging operation methods of RK3588EVB. It aims to help debuggers use RK3588EVB faster and more accurately, and be familiar with RK3588 chip development and application solutions.

Product version

The product versions corresponding to this document are as follows:

Product name	Product version
RK3588 EVB	RK_EVB1_RK3588_LP4XD200P232SD10H1_V10_20210818

Intended Audience

This guide is mainly intended for:

- Hardware development engineers
- Layout engineers
- Technical support engineers
- Test engineers

Revision History

This revision history recorded description of each version, and any updates of previous versions are included in the latest one.

Version No.	Author	Revision Date	Revision Description	Remark
V1.0	Lzx	2022-1-6	Initial release	

Acronyms

Acronyms include the abbreviations of commonly used phrases in this document:

Abbreviation	English meaning	Chinese meaning
CPU	Central Processing Unit	中央处理器
NPU	Neural Network Processing Unit	神经网络处理器
VPU	Video Processing Unit	视频处理器
DDR	Double Data Rate	双倍速率同步动态随机存储器
eMMC	Embedded Multi Media Card	内嵌式多媒体存储卡
eDP	Embedded DisplayPort	嵌入式数码音视频传输接口
HDMI	High Definition Multimedia Interface	高清晰度多媒体接口
I2C	Inter-Integrated Circuit	内部整合电路(两线式串行通讯总线)
I2S	Inter-IC Sound	集成电路内置音频总线
PMIC	Power Management IC	电源管理芯片
LDO	Low Drop Out Linear Regulator	低压差线性稳压器
DCDC	Direct Current to Direct Current	直流电转直流电
CAN	Controller Area Network	控制器局域网络
SARADC	Successive Approximation Register Analog to Digital Converter	逐次逼近寄存器型模数转换器
UART	Universal Asynchronous Receiver/ Transmitter	通用异步收发传输器
JTAG	Joint Test Action Group	联合测试行为组织
PWM	Pulse Width Modulation	脉冲宽度调制
MIPI	Mobile Industry Processor Interface	移动产业处理器接口
LVDS	Low-Voltage Differential Signaling	低电压差分信号
PMIC	Power Management IC	电源管理芯片
PMU	Power Management Unit	电源管理单元
RK/Rockchip	Rockchip Electronics Co.,Ltd.	瑞芯微电子股份有限公司
USB	Universal Serial Bus	通用串行总线
SATA	Serial Advanced Technology Attachment	串行高级技术附件
PCIe	Peripheral Component Interconnect Express	外围组件快速互连
RGB	Red,Green,Blue ; RGB color mode is a color standard in industry	红绿蓝, RGB 色彩模式, 是工业界的一种颜色标准
VGA	Video Graphics Array	电脑显示视频图像标准接口
ADB	Android Debug Bridge	安卓调试桥
IR	Infrared Radiation	红外线
SPDIF	Sony/Philips Digital Interface	索尼/飞利浦数字音频接口
RTC	Real-time clock	实时时钟
RGMII	Reduced Gigabit Media Independent Interface	精简吉比特介质独立接口
WIFI	Wireless Fidelity	无线保真
CIF	Camera Interface	摄像头接口

Contents

Preface II

Contents..... V

Figures VII

Tables.....IX

1 System Introduction 1

1.1 RK3588 Introduction 1

1.2 RK3588 Chip Block Diagram 2

1.3 System Framework 2

1.3.1 System Block Diagram 2

1.3.2 Function Summary 3

1.3.3 Functional Interface 4

1.3.4 Function Module Layout..... 5

1.4 Module 6

1.5 Power on and off and Standby 6

1.6 Firmware Upgrade 6

1.6.1 USB Driver Installation 6

1.6.2 Firmware Upgrade Method..... 7

1.7 Serial Debugging 9

1.7.1 Serial Port Tool..... 9

1.7.2 ADB Debug 11

2 Hardware Introduction..... 12

2.1 The Pictures 12

2.2 Power Block Diagram..... 13

2.3 I2C Address 13

2.4 Extension Connector Information 14

2.5 Reference Diagram 15

3 Module Brief 16

3.1 Power Input 16

3.2 Memory..... 16

3.3 RTC Circuit..... 18

3.4 Key Input 18

3.5 SATA Power Socket 19

3.6 PCIe Socket..... 19

3.7 Ethernet Port 20

3.8 SATA Interface..... 20

3.9 VGA Output..... 21

3.10 BT/WIFI Interface..... 21

3.11 Debug Interface..... 22

3.12 JTAG Interface..... 22

3.13 MIPI D/CPHY Input Interface 24

3.14 MIPI DPHY Input Interface..... 25

3.15 TYPEC Interface..... 27

3.16 USB3.0 Interface..... 28

3.17 USB2.0 Host Interface 29

3.18	HDMI Output Interface	29
3.19	HDMI Input Interface	30
3.20	Fan Power Connector	30
3.21	Sensor Module Expansion	31
3.22	Speaker Interface.....	32
4	Precautions.....	33

Figures

Figure 1-1 RK3588 Chip Block Diagram..... 2

Figure 1-2 RK3588 EVB1 System Block Diagram..... 3

Figure 1-3 EVB1 Functional Interface Distribution Diagram (front)..... 5

Figure 1-4 EVB1 Functional Interface Distribution Diagram (back)..... 5

Figure 1-5 Schematic Diagram of Successful Driver Installation 6

Figure 1-6 Schematic Diagram of Entering Loader Programming Mode..... 7

Figure 1-7 Schematic Diagram of Entering MASKROM Programming Mode 8

Figure 1-8 Get the Current Port COM Number 9

Figure 1-9 Serial Port Tool Configuration Interface..... 10

Figure 1-10 Serial Port Tool Debug Interface 11

Figure 1-11 ADB Connection is Normal..... 11

Figure 2-1 RK3588 EVB Picture..... 12

Figure 2-2 RK3588 EVB Block Diagram..... 13

Figure 2-3 Pitch 0.8mm Vertical Double Row 80 PIN PCB Package..... 15

Figure 3-1 DC12V Input, Front-end Buck Converter and PMIC Chip 16

Figure 3-2 Location of LPDDR4x and eMMC..... 17

Figure 3-3 Reserve Location of SPI Flash..... 17

Figure 3-4 Key Position of EVB into MASKROM Programming..... 17

Figure 3-5 RTC Circuit..... 18

Figure 3-6 Key Position..... 18

Figure 3-7 SATA Power 12V/5V Output..... 19

Figure 3-8 PCIe4 Socket..... 19

Figure 3-9 Gigabit Network Interface 20

Figure 3-10 UART Debug Interface..... 20

Figure 3-11 VGA Video Output Interface..... 21

Figure 3-12 BT/WIFI Antenna Interface 21

Figure 3-13 Debug Interface..... 22

Figure 3-14 JTAG Socket..... 23

Figure 3-15 DIP Switch..... 23

Figure 3-16 MIPID/CPHY RX Input Interface 24

Figure 3-17 MIPI DPHY Video Input Interface..... 26

Figure 3-18 TYPEC Interface..... 28

Figure 3-19 USB3.0 OTG Interface 28

Figure 3-20 USB2.0 Host Interface 29

Figure 3-21 HDMI TX Interface 29

Figure 3-22 HDMI RX Interface 30

Figure 3-23 Fan Power Interface 30

Figure 3-24 IMX415 Module Board.....	31
Figure 3-25 SPK Socket	32

Tables

Table 1-1 PCB Functional Interface Introduction Table 4

Table 2-1 Correspondence Table of Peripheral Address and IO Level Value Mounted on I2C Channel 13

Table 3-1 MIPID/CPHY_RX Signal Definition Table..... 24

Table 3-2 MIPI DPHY_RX Signal Definition Table 26

Table 3-3 IMX415 Module Expansion Interface Signal Definition Table 31

1 System Introduction

1.1 RK3588 Introduction

RK3588 is a high-performance, low-power application processor chip. It integrates 4 Cortex-A76, 4 Cortex-A55 and independent NEON coprocessor. Suitable for ARM PC, edge computing, personal mobile Internet devices and other multimedia products.

RK3588 has built-in a variety of powerful embedded hardware engines, providing excellent performance for high-end applications. It supports 8K@60fps H.265 and VP9 decoder, 8k@30fps H.264 decoder and 4K@60fps AV1 decoder; it also supports 8K@30fps H.264 and H.265 encoder, high quality JPEG encoder/decoder, dedicated image pre-processor and post-processor.

RK3588 has a built-in 3D GPU that is fully compatible with OpenGL ES1.1/2.0/3.2, OpenCL 2.2 and Vulkan 1.2. The special 2D hardware engine with MMU will maximize the display performance and provide a smooth operating experience.

RK3588 introduces a new generation of ISP with the largest 48M pixels completely based on hardware. It implements many algorithm accelerators, such as HDR, 3A, LSC, 3DNR, 2DNR, sharpening, defogging, fisheye correction, gamma correction, etc.

The NPU embedded in RK3588 supports INT4/INT8/INT16/FP16 mixed operation, and the computing power is up to 6TOP. In addition, with its strong compatibility, network models based on a series of frameworks such as TensorFlow/MXNet/PyTorch/Caffe can be easily converted.

RK3588 has high-performance 4-channel external memory interfaces (LPDDR4/LPDDR4X/LPDDR5), which can support systems with high memory bandwidth requirements, and also provides a complete set of peripheral interfaces to flexibly support various Class application.

1.2 RK3588 Chip Block Diagram

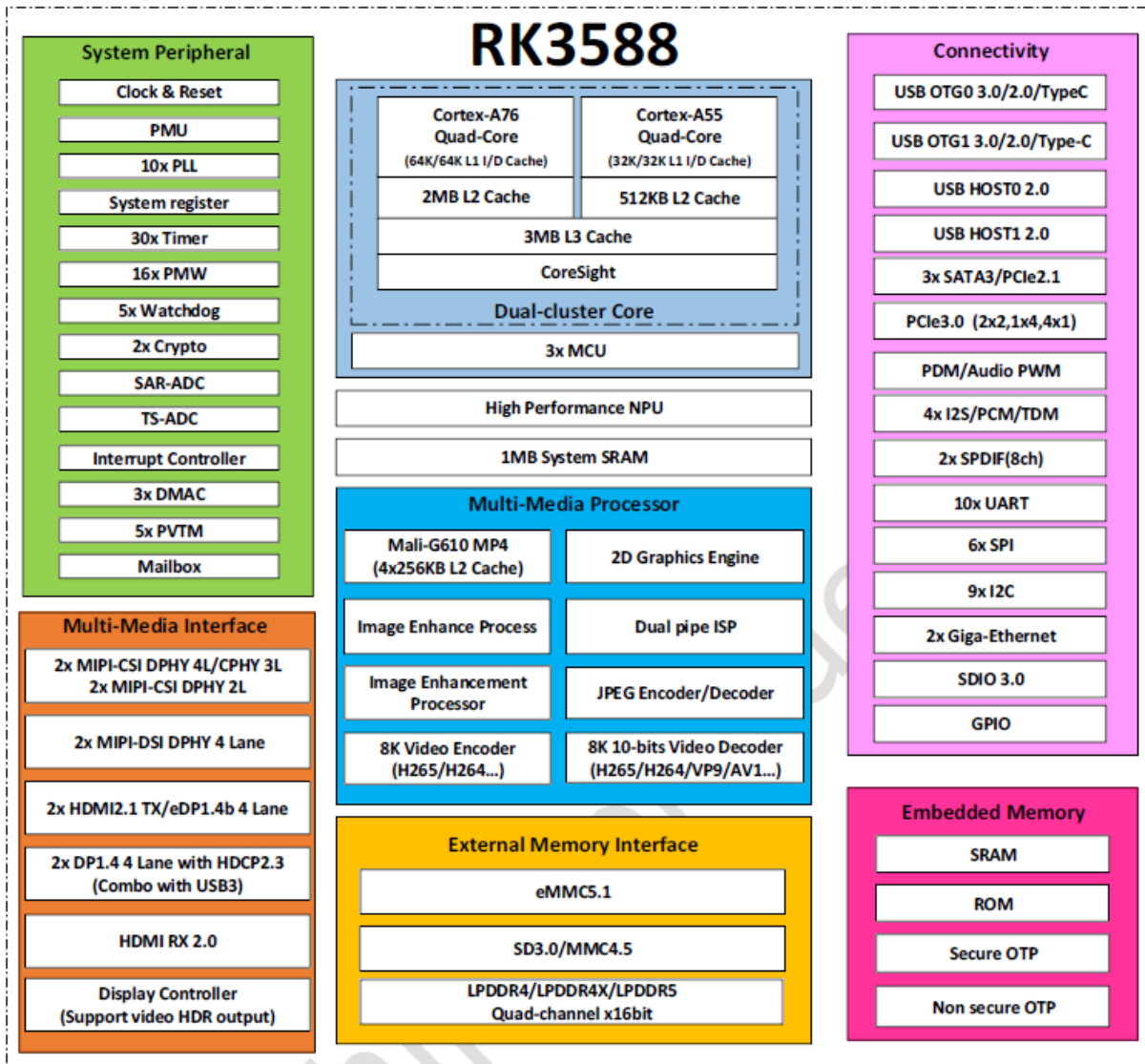

Figure 1-1RK3588 Chip Block Diagram

1.3 System Framework

1.3.1 System Block Diagram

RK3588 EVB system uses RK3588 as the core chip of the system, and two power supply schemes, RK806-2 dual PMIC or RK806-1 single PMIC can be selected. Use LPDDR4X, eMMC, MIPI TX, and SATA/PCIe and other functional external device interfaces to integrate a stable and mass-produced solution. The detailed system block diagram is as follows:

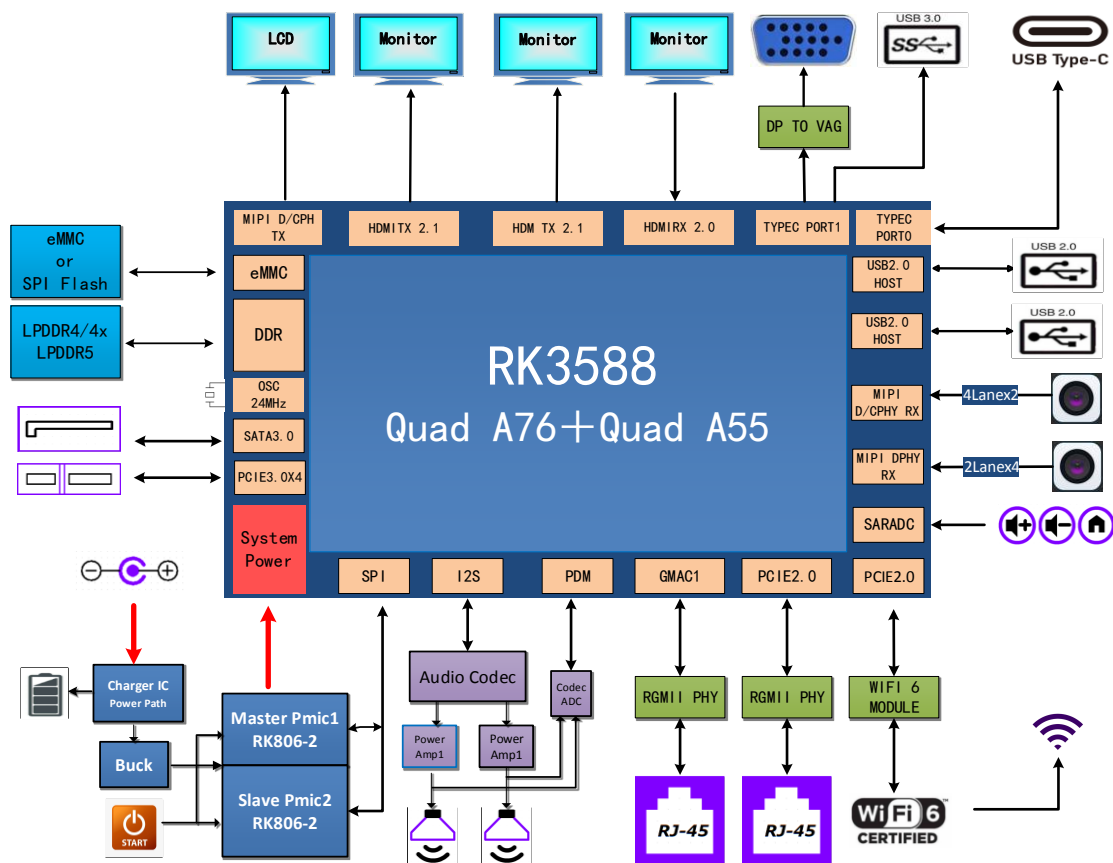

Figure 1-2RK3588 EVB1 System Block Diagram

1.3.2 Function Summary

RK3588 EVB includes the following functions:

- DC Power: DC 12V adapter power supply interface;
- TYPEC: One complete TYPEC interface, compatible with system firmware upgrade channel and DP1.4 output interface;
- USB2.0 HOST0/1: Two-way USB2.0standard-A interface, can connect to mouse, U disk, USB HUB and other equipment;
- MIPI DCPHY: Support two channels of 4lane MIPI DPHY or two channels of 3lane MIPICPHY signal input,access via 80pin socket;
- MIPI DPHY: Support two channels of 4lane or four channels of 2lane MIPI signal input, access via 80pin socket;
- HDMI2.1 OUT: Two HDMI2.1 OUT standard-A interfaces, a single channel can support up to 8K@60Hz output;
- MIPI DPHY0/1 TX: Support two channels of 4lane MIPI signal output, access via FPC line;
- VGA OUT: DP signal convert to VAG output
- PCIe Wi-Fi(2T2RWifi6&BT5.0): Wi-Fi model is AP6275P/AP6275PR3, external SMA antenna, support wireless Internet function
- Ethernet: Support two channels RJ45 ports 10/100/1000M Ethernet;

- Audio Interface:Support speaker, earphone output sound, single MIC recording
- SATA3.0Interface: Two 7pin SATA interface
- PCIe3.0 Interface: One standard PCIex4 interface, used to expand PCIe devices;
- UART Debug: User debugging to view the LOG information; support TYPEC and MINI USB interface;
- JTAG: JTAG debug interface of system;
- System Key: Include Reset, MASKROM,PWRON,V+/Recover,V-,MENU,ESC button;
- SPDIF: Support digital audio interface;
- RTC: Using HYM8563TS chip, can be powered by development board or button battery (CR1220-3V)

1.3.3 Functional Interface

Table 1-1PCB Functional Interface Introduction Table

Function	usable or not
LPDDR4x(total capacity8GB)	YES
eMMC(total capacity32GB)	YES
SPI Flash	No patch by default
DC 12V Input	YES
USB3.0 OTG(1 Port)	YES
USB2.0 Host(2 Port)	YES
MIPI D/CPHY RX	YES
MIPI DPHY RX	YES
HDMI2.0 RX	YES
HDMI2.1 OUT(2 Port)	YES
MIPI DPHY DSI TX1(2x4lane)	YES
VGA OUT	YES
BT&PCIe Wifi(2x2 Wifi&BT5.0)	YES
1000 Mbps Ethernet port 10M/100M/1000M(2 Port)	YES
Audio(SPK、MIC、Earphone)	YES
SATA3.0 Interface(2 Port)	YES
PCIe3.0 Interface(4Lane)	YES
UART Debug(TPYEC/MINI USB)	YES
JTAG Interface	YES
System Key	YES
Maskrom Key	YES

1.3.4 Function Module Layout

EVB1 functional interface distribution diagram:

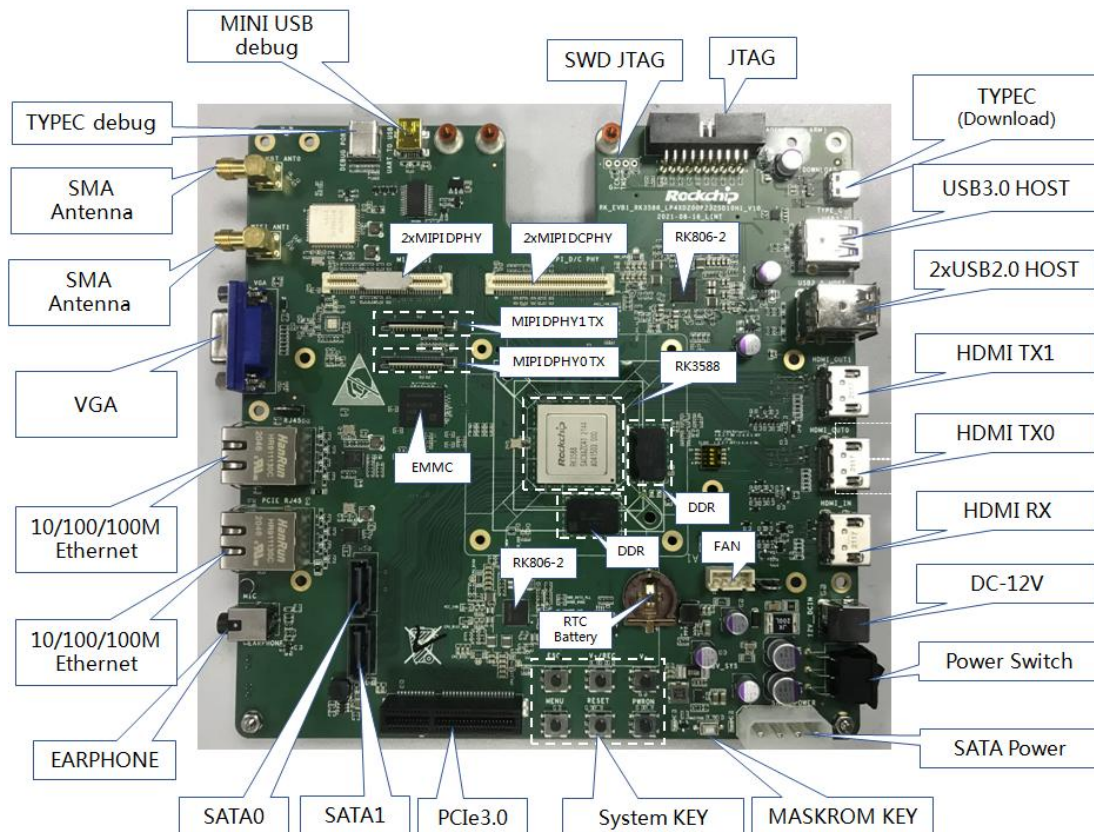

Figure 1-3EVB1 Functional Interface Distribution Diagram(front)

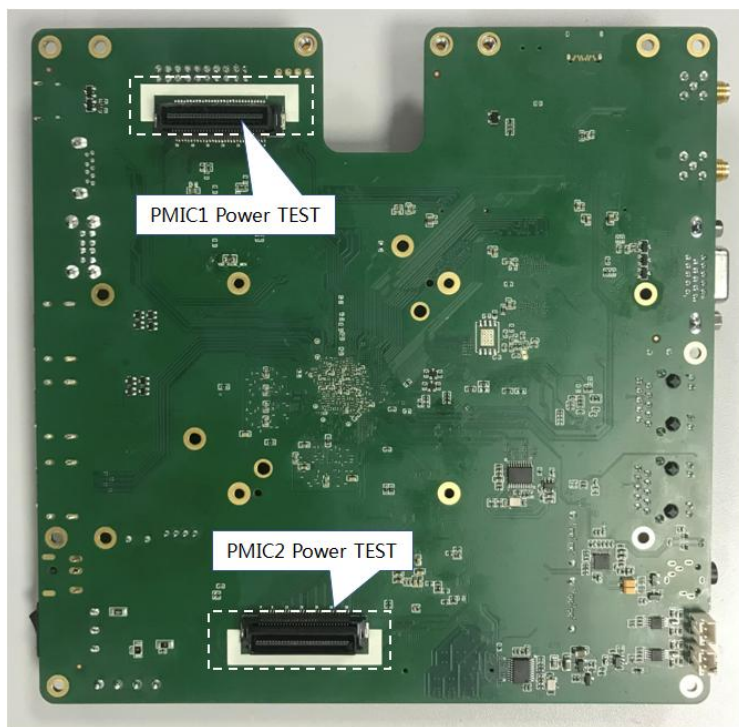

Figure 1-4EVB1 Functional Interface Distribution Diagram(back)

1.4 Module

The RK3588 EVB kit includes the following items:

- RK3588EVB
- Power adapter, default specification: input 100V AC~240V AC, 50Hz; output 12V DC, 3A
- Display, specification: MIPI; size: 5.5 inches/vertical screen; resolution: 1920*1080
- One 2.4G/5G dual-band SMA male connector antennas
- IMX415 monocular cameramodule

1.5 Power on and off and Standby

The EVB power on, power off and standby methods are introduced as follows:

- Power on: Use DC 12V power supply, turn on the main power switch; wait to enter the Android interface, it means that the default firmware has been successfully started.
- Power off: Press and hold the power button for 6 seconds to shut down the system.
- Standby: Press the power button, the system will enter the first-level standby state. **When there is no USB OTG connection, and there is no other operation (such as key operation), and the software does not have a Wake_Lock source. After about 3s, it will switch from the first-level standby to the second-level standby state. Standby mode can be launched through the Power button.**

1.6 Firmware Upgrade

1.6.1 USB Driver Installation

The driver needs to be installed before the EVB driver is upgraded. The following describes the driver installation process under Windows system.

Find **DriverAssitant_v5.1.1** in the provided tool folder, and click **DriverInstall.exe** to pop up the following interface. Click "Install Driver" and wait for the prompt to install the driver successfully. If the old driver has been installed, please click "Uninstall Driver " and reinstall the driver.

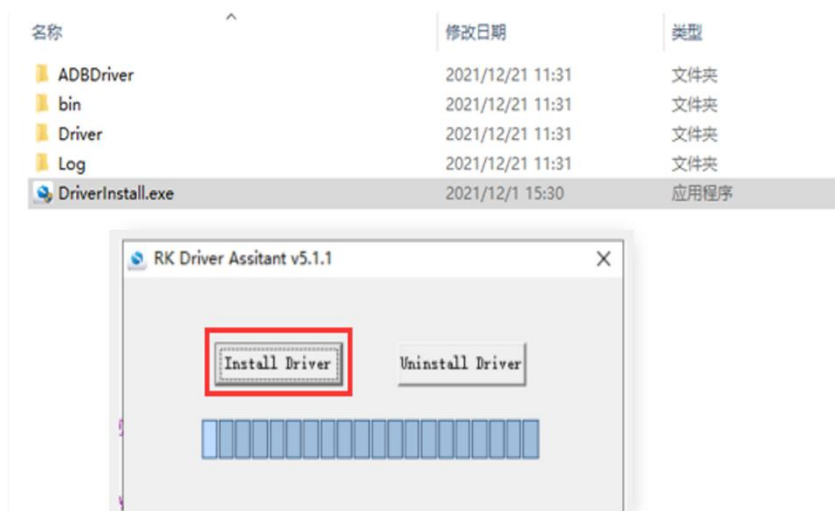

Figure 1-5 Schematic Diagram of Successful Driver Installation

1.6.2 Firmware Upgrade Method

There are two ways to upgrade RK3588 EVB firmware:

- Enter Loader upgrade mode:

Before the system is powered on, SARADC_IN1 needs to be kept low, and the system will enter the Loader state.

Specific steps are as follows:

- 1) Connect the TYPE_C port to the computer, press and hold the V+/REC button on the mainboard.
- 2) EVB is powered by 12V. If it has been powered on, press the reset button.
- 3) After the programming tool shows that “a Loader device is found”, release the V+/REC button. In the red rectangular area of the tool, right-click and choose "Import Configuration", then find the firmware path, and select the config file
- 4) The programming tool corresponds to selecting Loader, Parameter, Uboot and other files.
- 5) Click Execute to enter the upgrade state. The right side of the tool is the progress display bar, which displays the download progress and verification status.

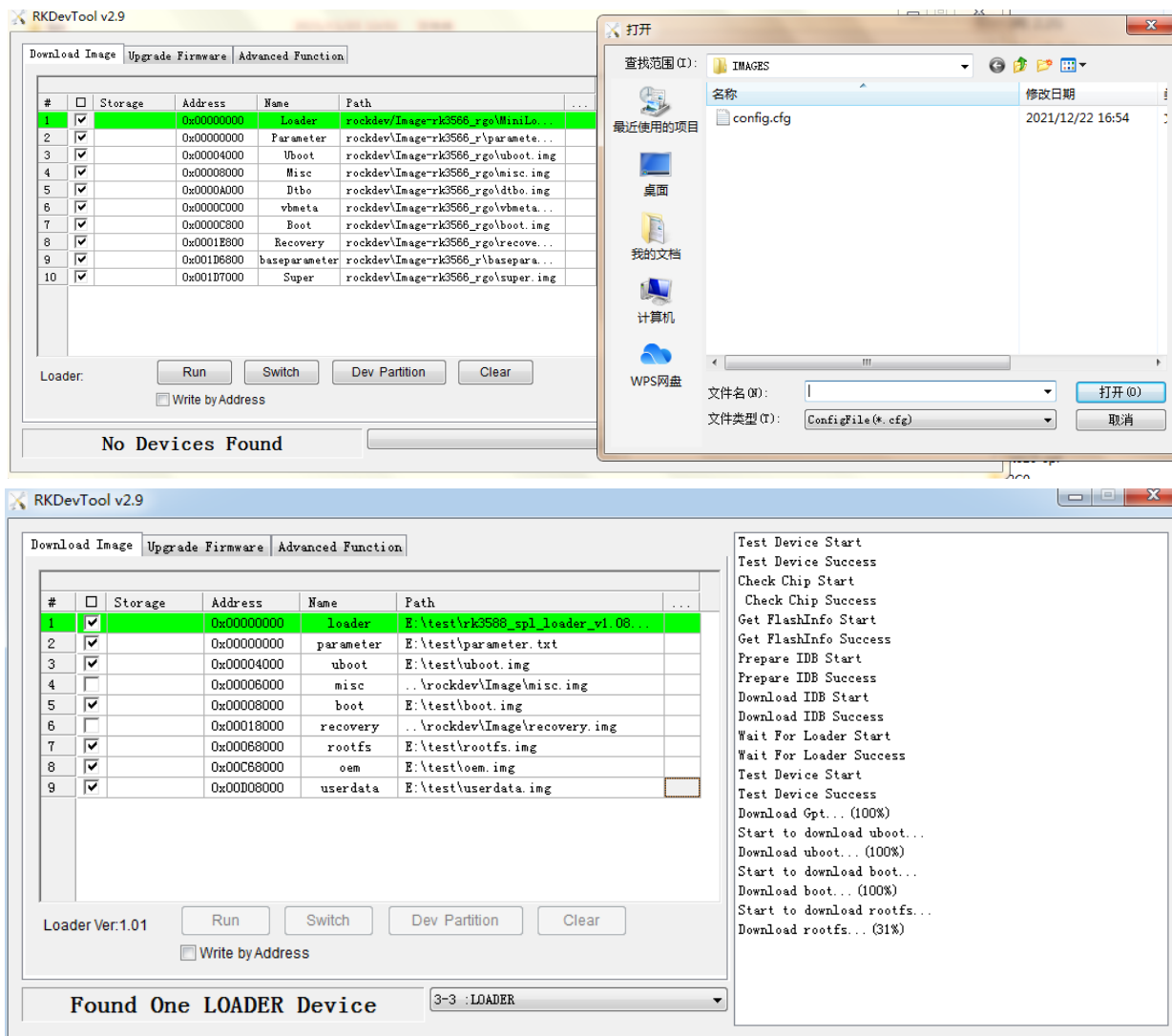

Figure 1-6 Schematic Diagram of Entering Loader Programming Mode

- Enter MASKROM upgrade mode:

Before the system is powered on, SARADC_IN0 is low and enters the MASKROM state.

Specific steps are as follows:

- 1) Connect the TYPE_C port to the computer, press and hold the MASKROM button on the board.
- 2) EVB is powered by 12V. If it has been powered on, press the reset button.
- 3) After the programming tool shows that “a MASKROM device is found”, release the MASKROM button. In the red rectangular area of the tool, right-click and choose "Import Configuration", then find the firmware path, and select the config.cfg file
- 4) The programming tool correspondingly selects Loader, Parameter, Uboot and other files.
- 5) Click Execute to enter the upgrade state. The right side of the tool is the progress display bar, which displays the download progress and verification status.

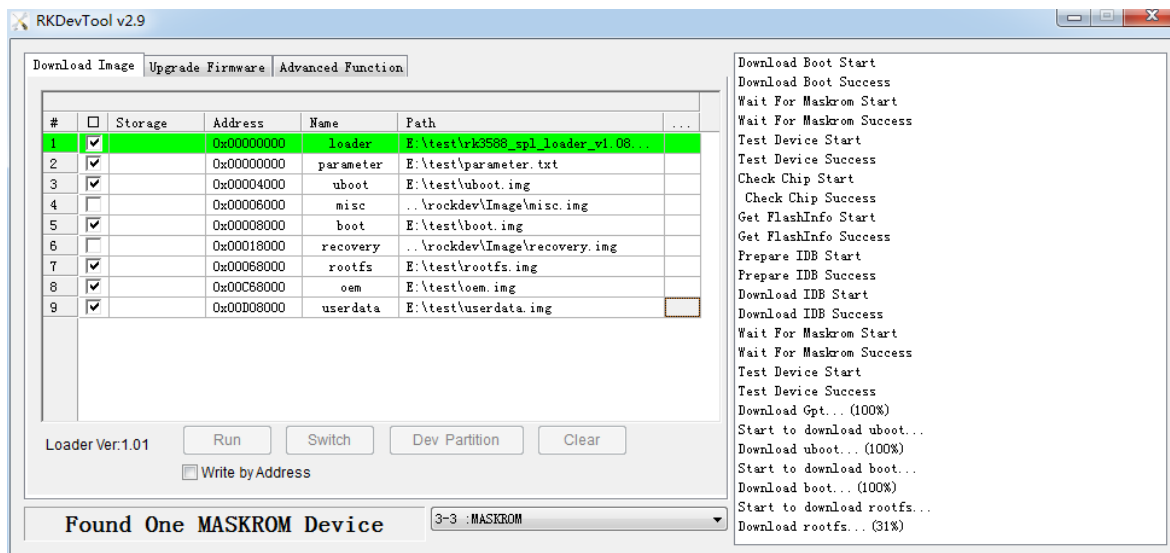
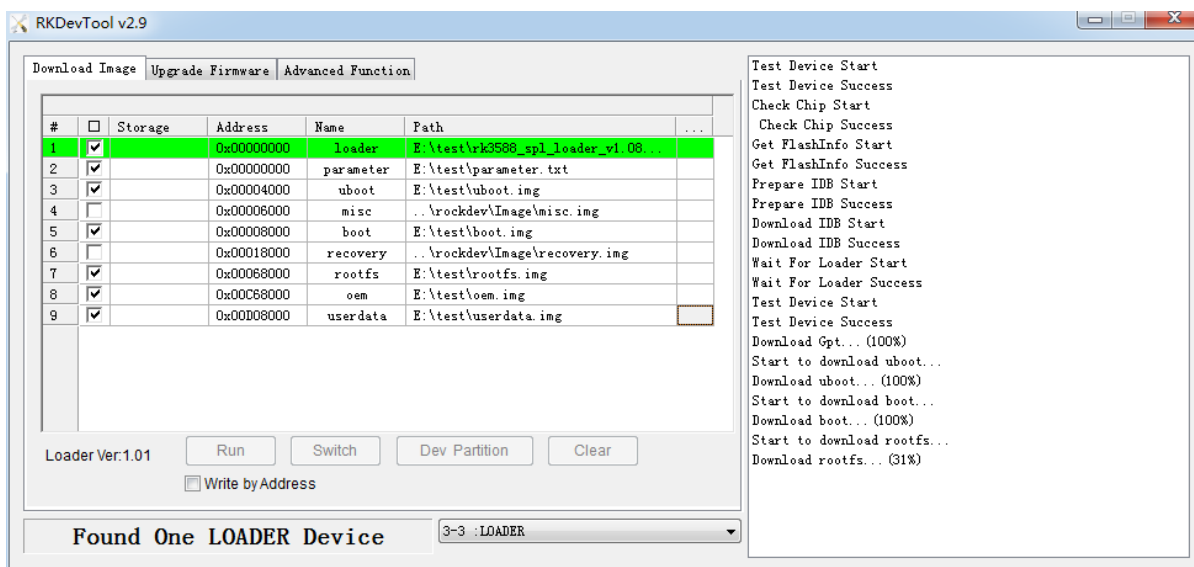

Figure 1-7Schematic Diagram of Entering MASKROM Programming Mode

1.7 Serial Debugging

1.7.1 Serial Port Tool

Connect the MINI USB Debug debugging interface of the development board to the the computer, and get the current port COM number in the device manager of the PC end.

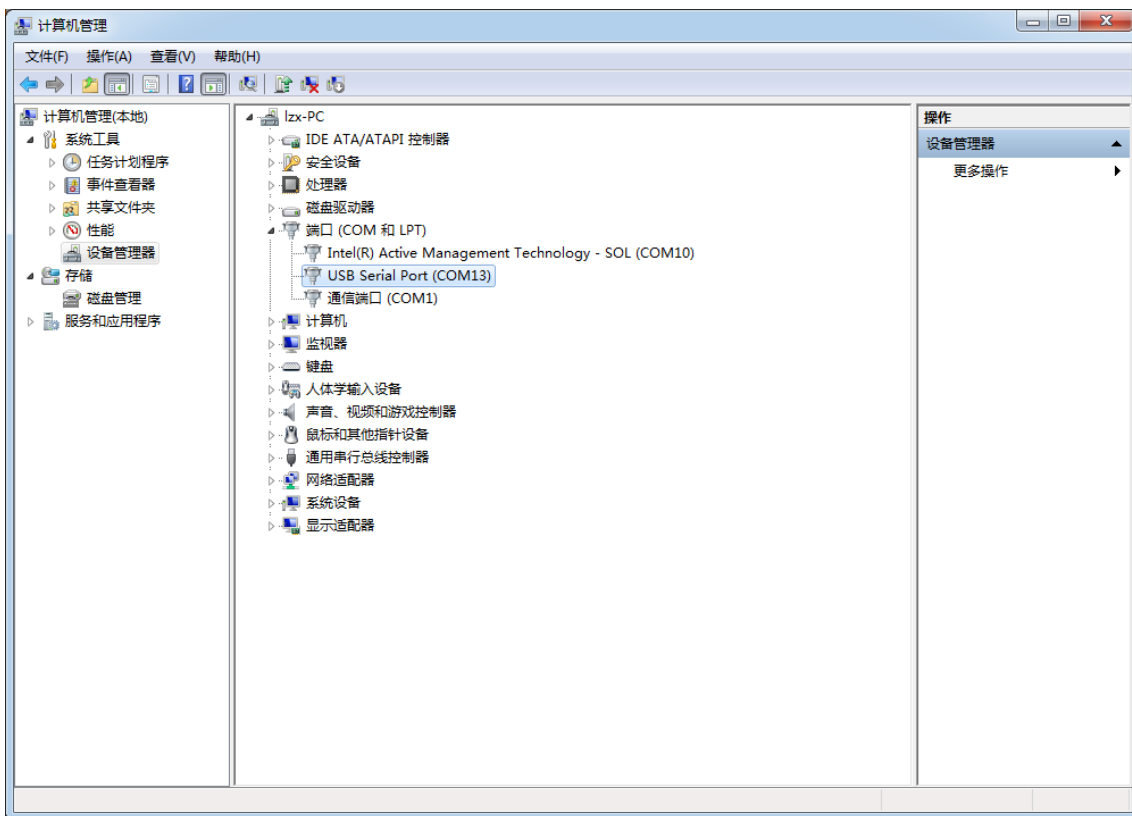

Figure 1-8Get the Current Port COM Number

Open the serial port tool, under the "Quick Connect" interface, first select the serial port, then select the corresponding serial port number, change the baud rate to 1.5M (RK3588 supports 1.5M baud rate by default), and close the flow control at Serial, Finally, click the "Open" button to enter the serial port debugging interface.

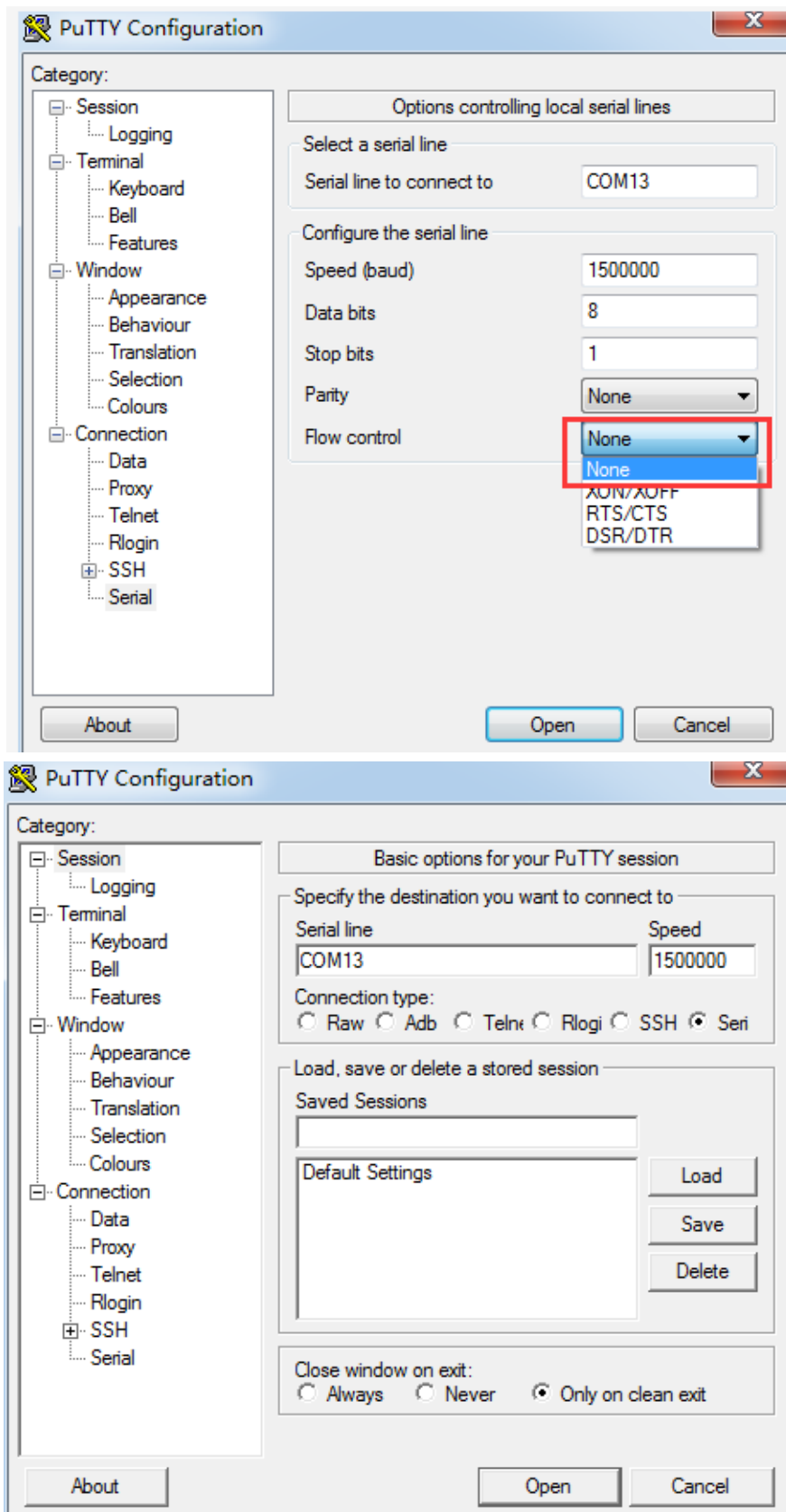

Figure 1-9Serial Port Tool Configuration Interface

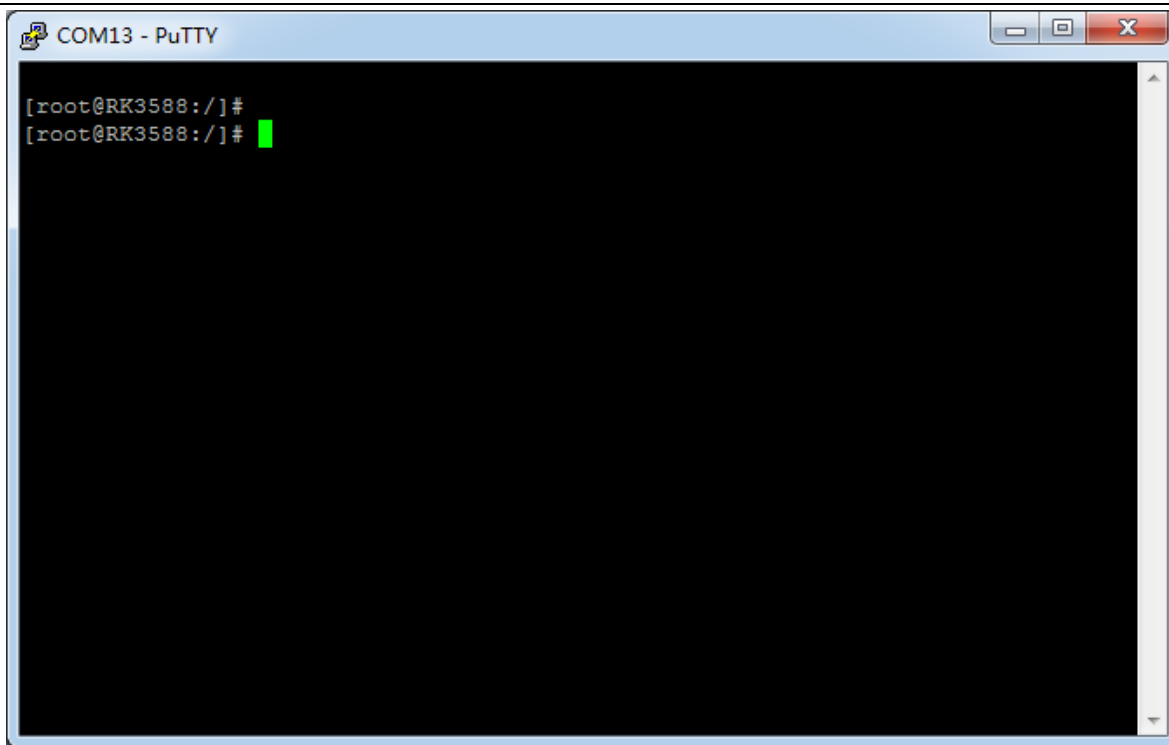

Figure 1-10 Serial Port Tool Debug Interface

1.7.2 ADB Debug

- 1) Ensure that the driver is installed successfully, and the PC is connected to the TYPE_C port on the same side as the power supply of the development board;
- 2) Power on the development board and boot into the system;
- 3) Open the adb tool on the PC side;
- 4) Type "adb shell" to enter adb debugging.

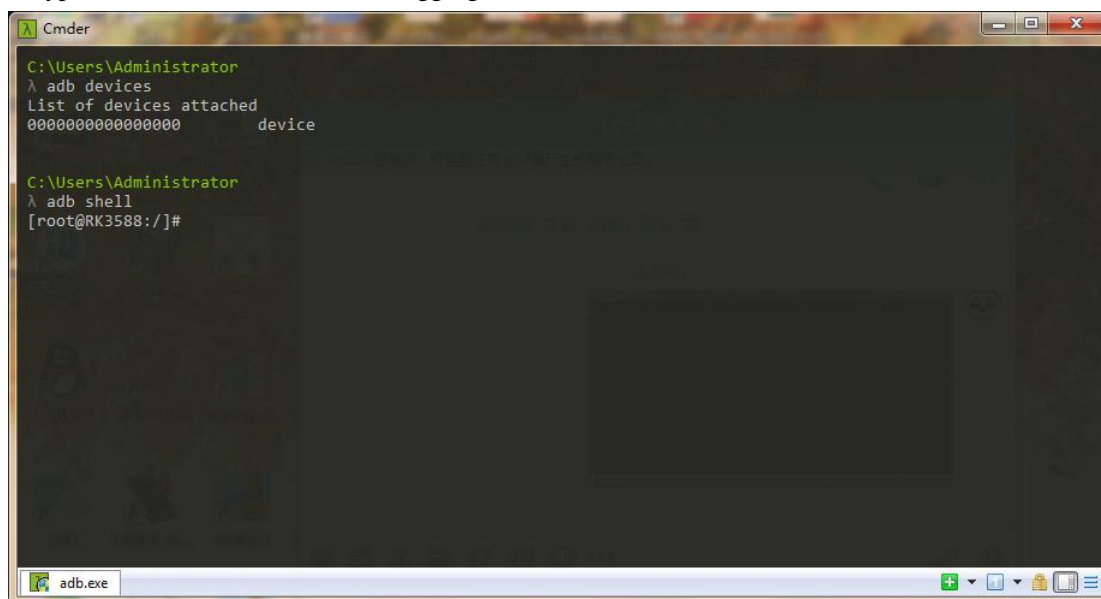

Figure 1-11 ADB Connection is Normal

2 Hardware Introduction

2.1 The Pictures

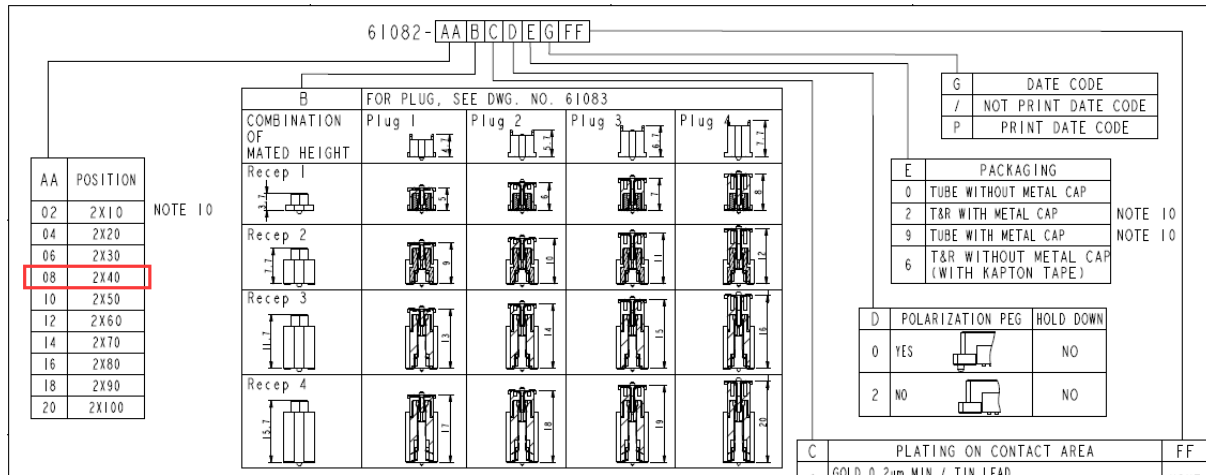

Figure 2-1RK3588 EVBPicture

2.4 Extension Connector Information

In actual use, the user may make an expansion board. The model of the development board connector is as follows:

U4600 and U4700 are vertical double-row 80PIN card sockets with 0.3mm pins and 0.8mm spacing. The dimensions are as follows:



PRODUCT NO.	NUMBER OF POSITIONS	DIMENSION		
		A	B	C
61082-041***	2X20	15.2	21.8	20.2
61082-061***	2X30	23.2	29.8	28.2
61082-081***	2X40	31.2	37.8	36.2
61082-101***	2X50	39.2	45.8	44.2
61082-121***	2X60	47.2	53.8	52.2
61082-141***	2X70	55.2	61.8	60.2
61082-161***	2X80	63.2	69.8	68.2
61082-181***	2X90	71.2	77.8	76.2
61082-201***	2X100	79.2	85.8	84.2

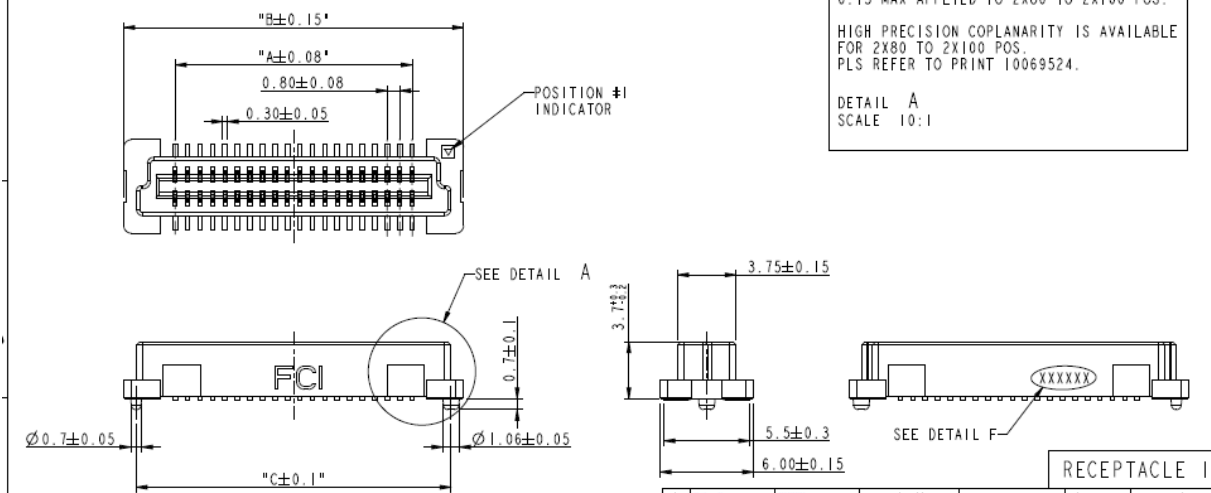
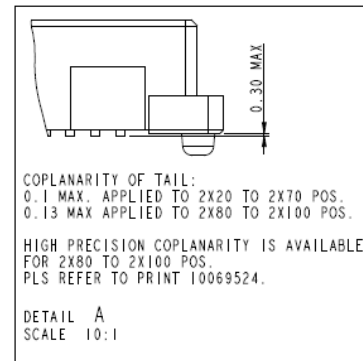
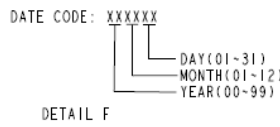

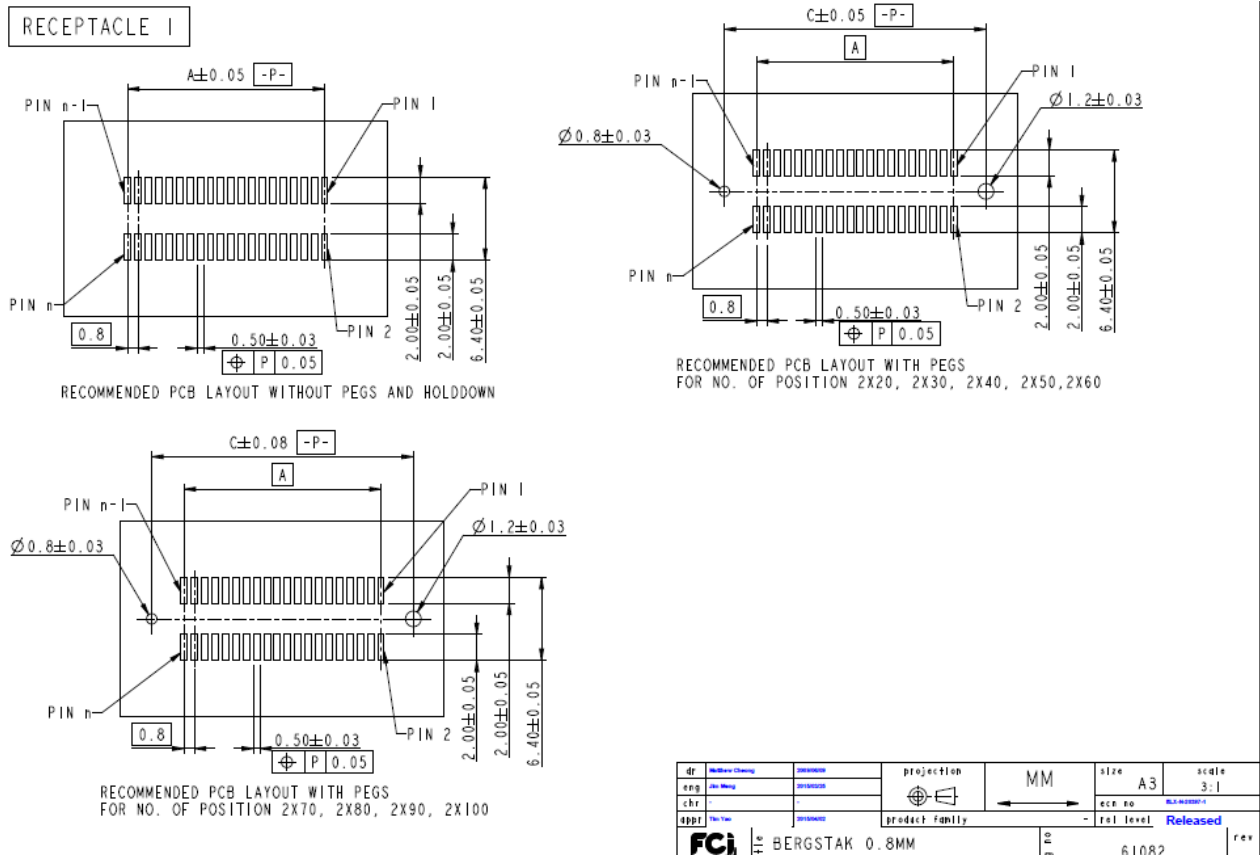

Figure 2-3Pitch 0.8mm Vertical Double Row 80 PIN PCB Package

2.5 Reference Diagram

The reference diagram and PCB design information corresponding to the EVB are as follows:

- Reference diagram: RK_EVB1_RK3588_LP4XD200P232SD10H1_V10_20210818RZF.DSN;
- PCB design: RK_EVB1_RK3588_LP4XD200P232SD10H1_V10_20210817_final_lint.brd.

3 Module Brief

3.1 Power Input

The power adapter inputs 12V/3A power, after passing the front-end buck converter power supply, the system power VCC5V0_SYS is obtained, and then the system voltage is provided to the PMIC power management chip, and different voltages are output for system use.

Power adapter input port, front-end Buck converter and PMIC chip:

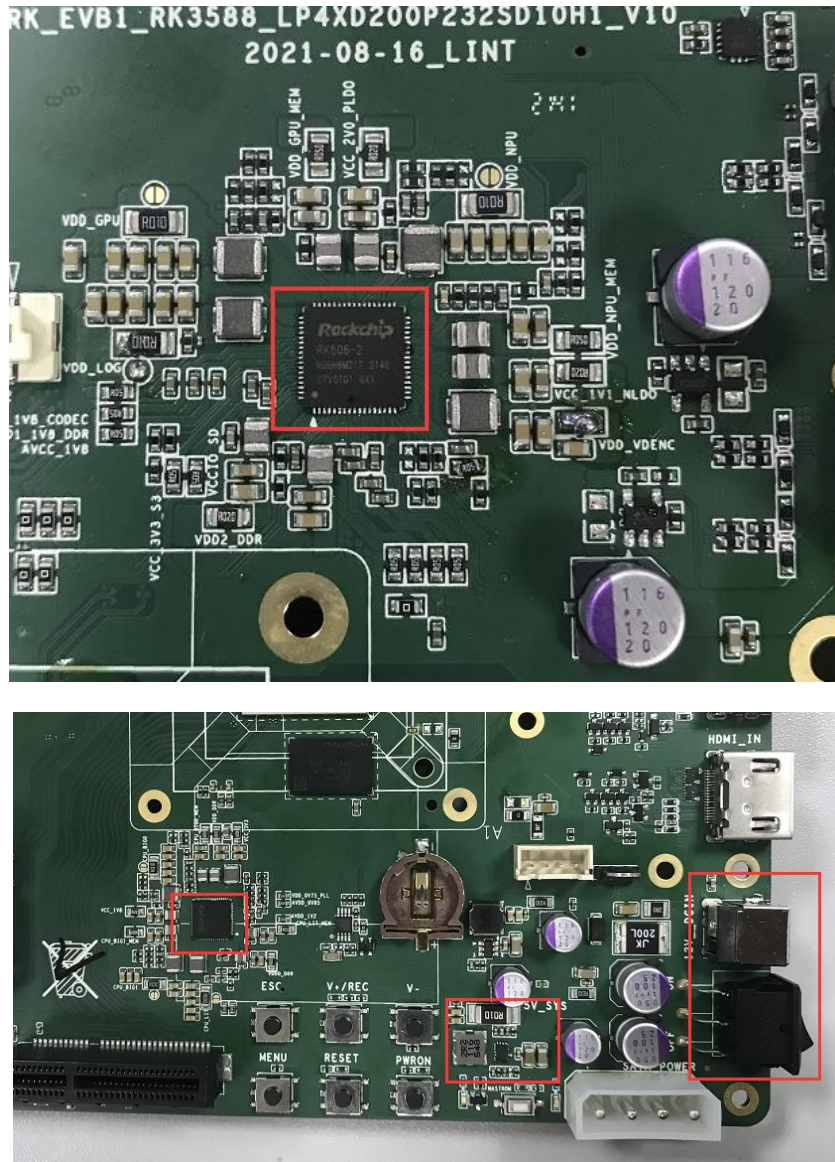

Figure 3-1DC12V Input, Front-end Buck Converter and PMIC Chip

3.2 Memory

- eMMC: The storage type on the development board is eMMC FLASH, and the default capacity is 32GB;
- SPI Flash: The development board reserves the location of the SPI device;
- DDR: The development board DDR adopts two pieces of 4GB LPDDR4x, with a total capacity of 8GB.

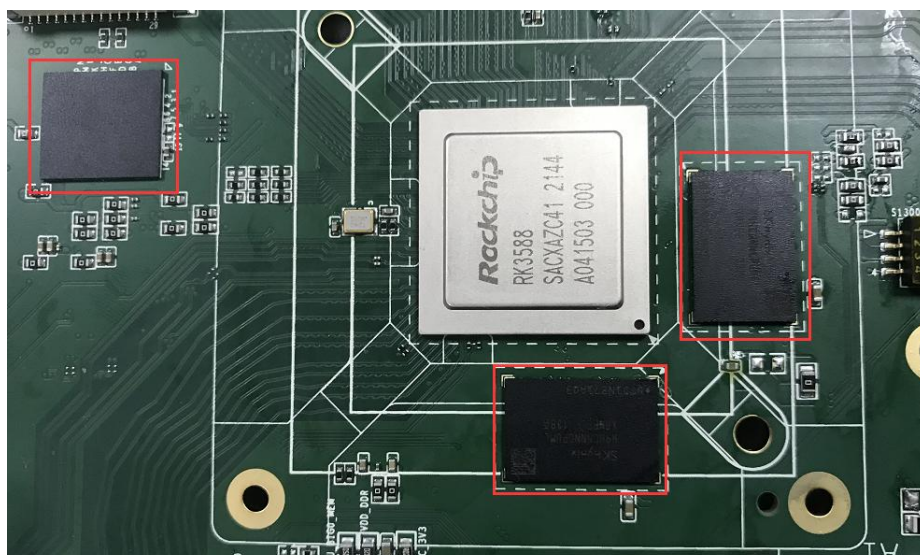

Figure 3-2 Location of LPDDR4x and MMC

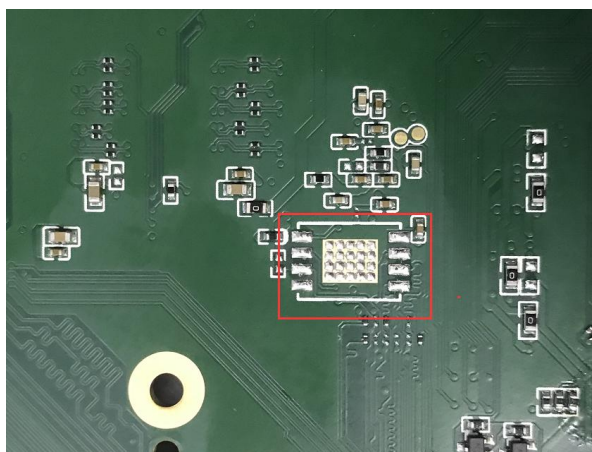

Figure 3-3 Reserve Location of SPI Flash

The key position of EVB into MASKROM programming:

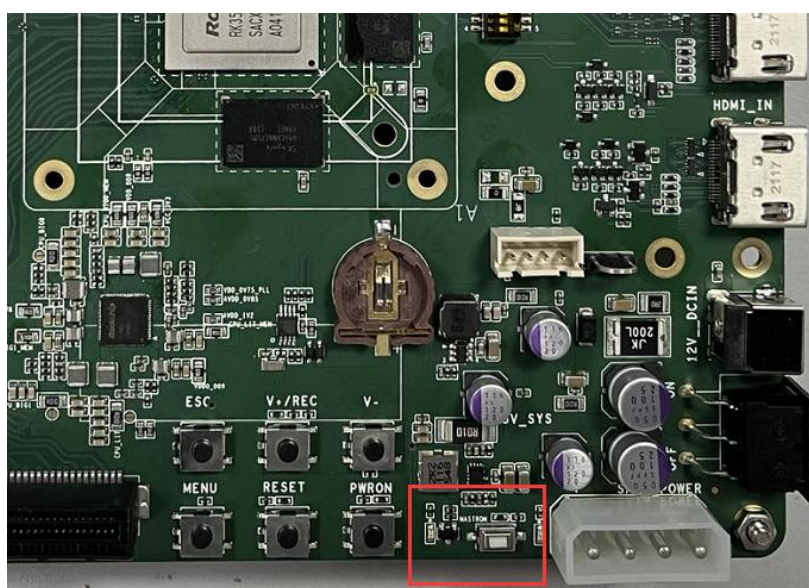

Figure 3-4 Key Position of EVB into MASKROM Programming

3.3 RTC Circuit

The RTC circuit adopts the HYM8563TS chip, which can be powered by the development board or its own button battery (not included by default, you need to purchase a CR1220-3V button battery by yourself), to ensure that it can continue to provide accurate time even when the board is powered off, and communicate with master through the I2C signal.

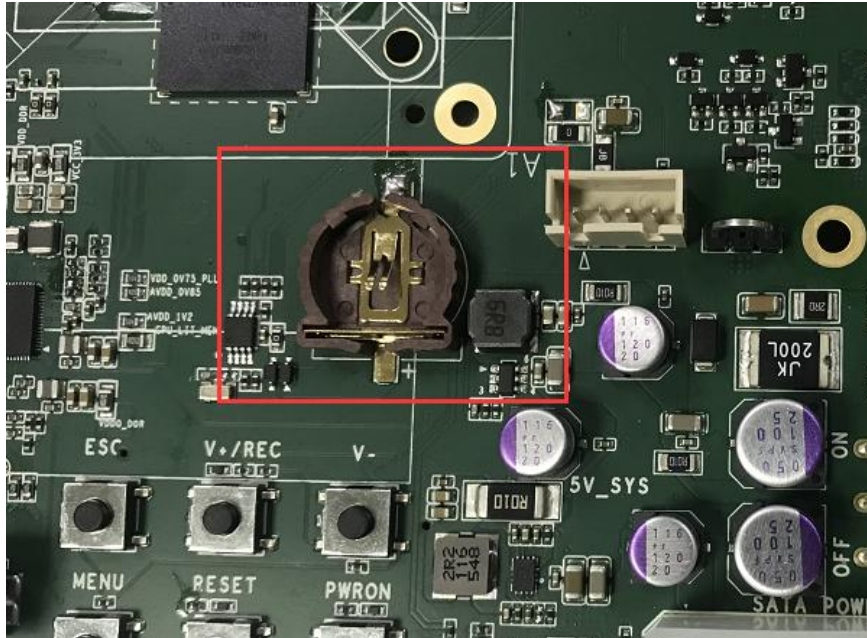

Figure 3-5 RTC Circuit

3.4 Key Input

The development board uses SARADC_IN1 as the RECOVER detection port, supports 12-bit resolution, and can enter the LOADER programming mode through the V+/REC button. In addition, the board also has a RESET button, which is convenient to reset and restart the machine through hardware; and other commonly used several Buttons: V+, V-, ESC, MENU, PWRON.

The key positions are as follows:

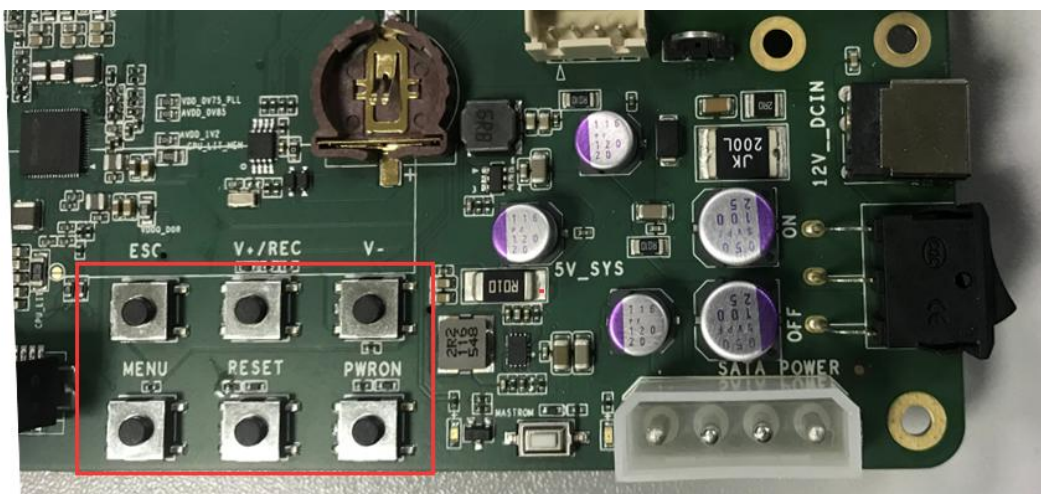

Figure 3-6Key Position

3.5 SATA Power Socket

The SATA device power supply ports used by the development board output 12V/5V respectively.

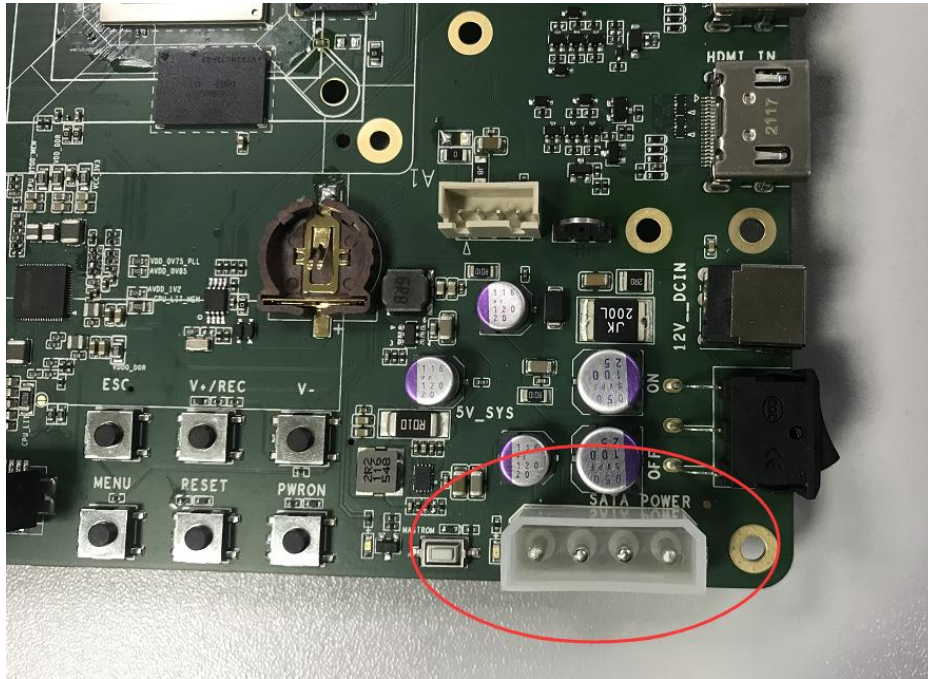

Figure 3-7SATA Power 12V/5V Output

3.6 PCIeSocket

The development board uses a standard PCIe3.0 connector, which can be connected to an external PCIe card for communication.

- Working mode: End Point(EP) &Root Complex(RC).
- The link supports 4 lane data interfaces.
- The 100MHz clock is provided by the external clock chip PI6C557-05BLE.

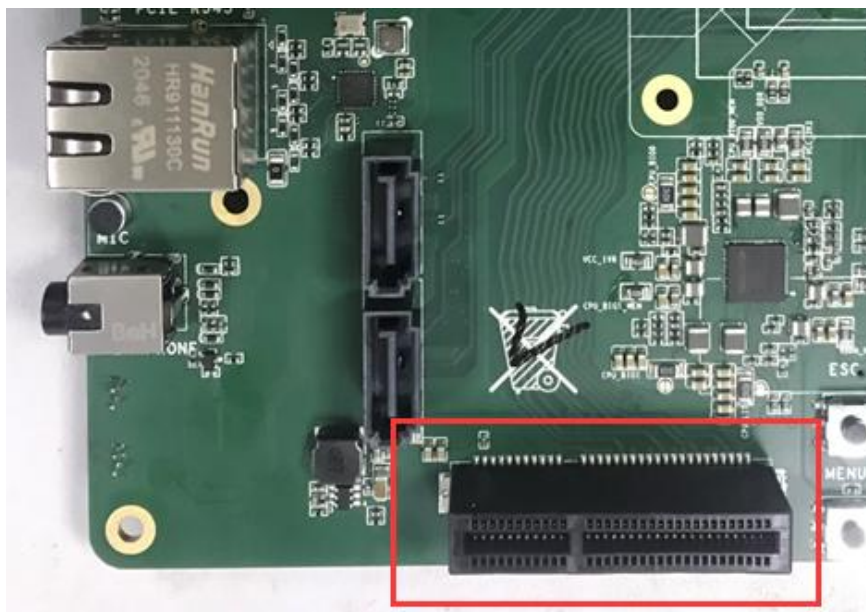

Figure 3-8PCIex4 Socket

3.7 Ethernet Port

The development board supports two RJ45 ports, which can provide dual Gigabit Ethernet connection function. The internal integrated Gigabit Ethernet MAC and PCIe2.0 are respectively used to connect with the external PHY chip. The PHY model is RTL8211F-CG/RTL8111HS. The characteristics are as follows:

- Compatible with IEEE802.3 standard, support full-duplex and half-duplex operation, support cross detection and self-adaptation.
- Support 10/100/1000M data rate.
- The interface adopts the combination of RJ45 interface with isolation transformer and indicator light.

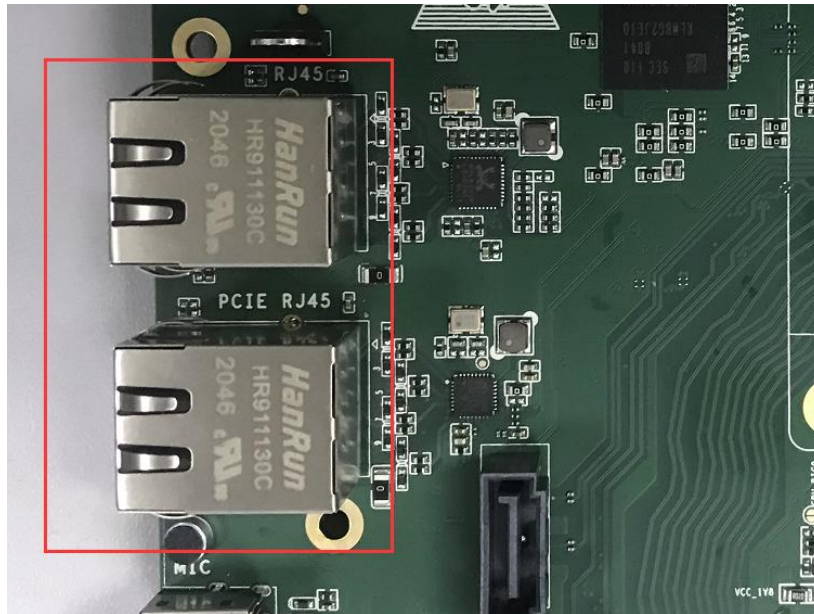

Figure 3-9Gigabit Network Interface

3.8 SATAInterface

The development board provides two 7P SATA ports.

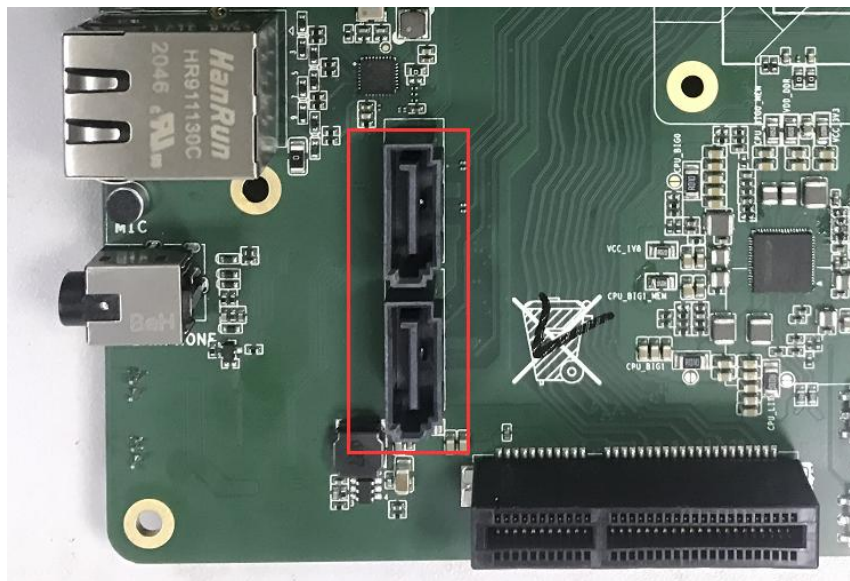

Figure 3-10UART Debug Interface

3.9 VGAOutput

The development board supports standard VGA interface video output, and is pasted with the RTD2166 chip by default.

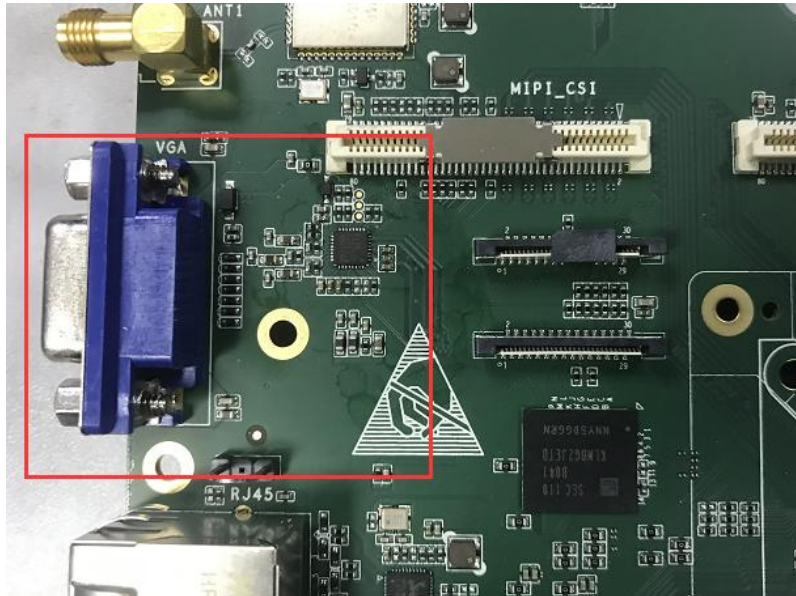

Figure 3-11VGA Video Output Interface

3.10 BT/WIFIInterface

The WIFI+BT module on the board adopts AMPAK AP6275P, and the characteristics are as follows:

- Support 2x2WIFI (2.4G and 5G, 802.11 a/b/g/n/ac), BT5.0 function, and 2 external SMA interface antennas.
- BT data adopts UART communication mode.
- BT voice is connected to the master I2S interface.
- WIFI data adopts PCIe data bus.

RK3588 EVB is equipped with two 2.4GHz/5GHz dual-mode antennas by default.

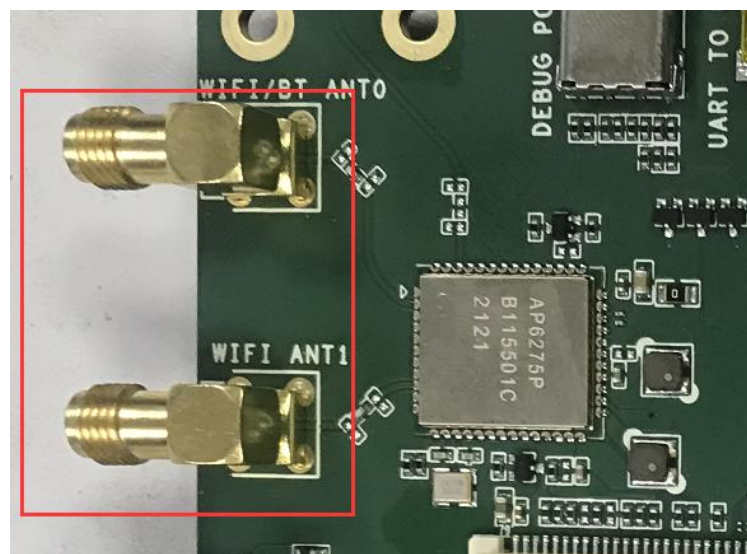

Figure 3-12BT/WIFI Antenna Interface

3.11 DebugInterface

The development board supports TYPEC and MINI USB debugging interfaces.

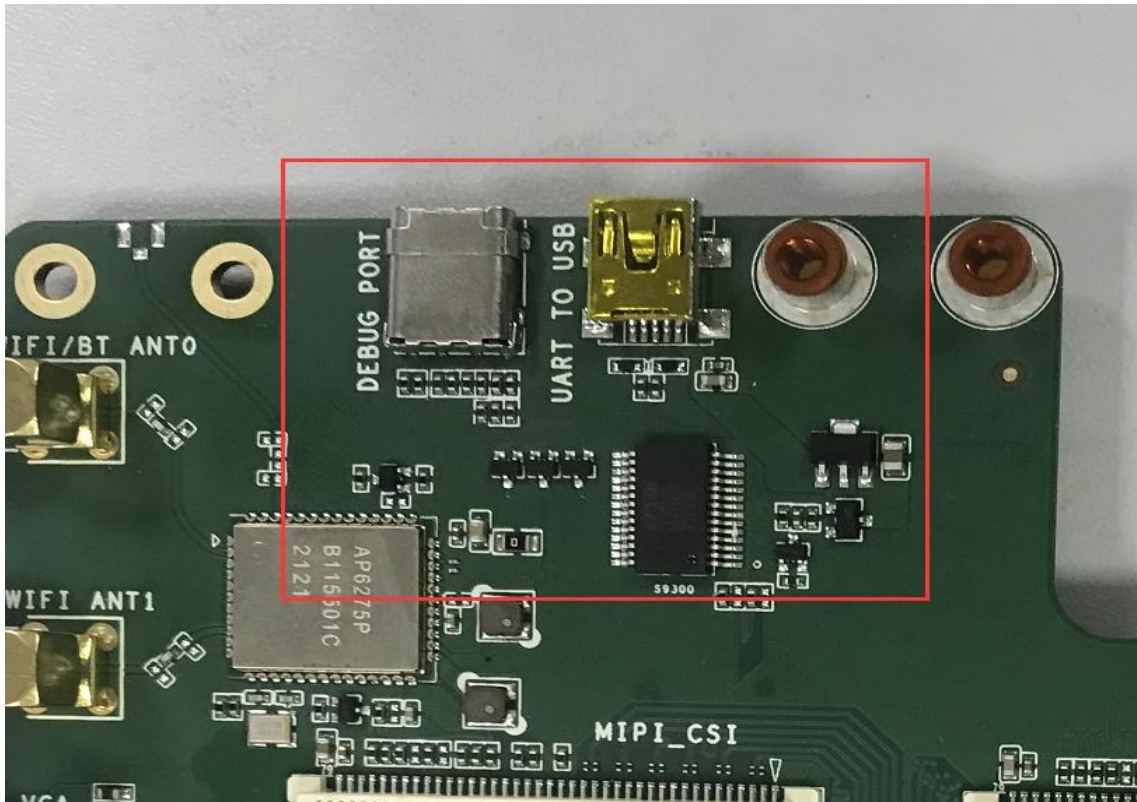

Figure 3-13 DebugInterface

3.12 JTAGInterface

The development board reserves 2xJTAG interfaces, and the reserved interface in the figure below is ARM JTAG. The standard JTAG socket supports ARM/MCU JTAG, which can be switched by the DIP switch; when the switch 1/2 is turned on and 3/4 is turned off, it supports ARM JTAG, and when the switch 1/2 is turned off and 3/4 is turned on, it supports MCU JTAG.

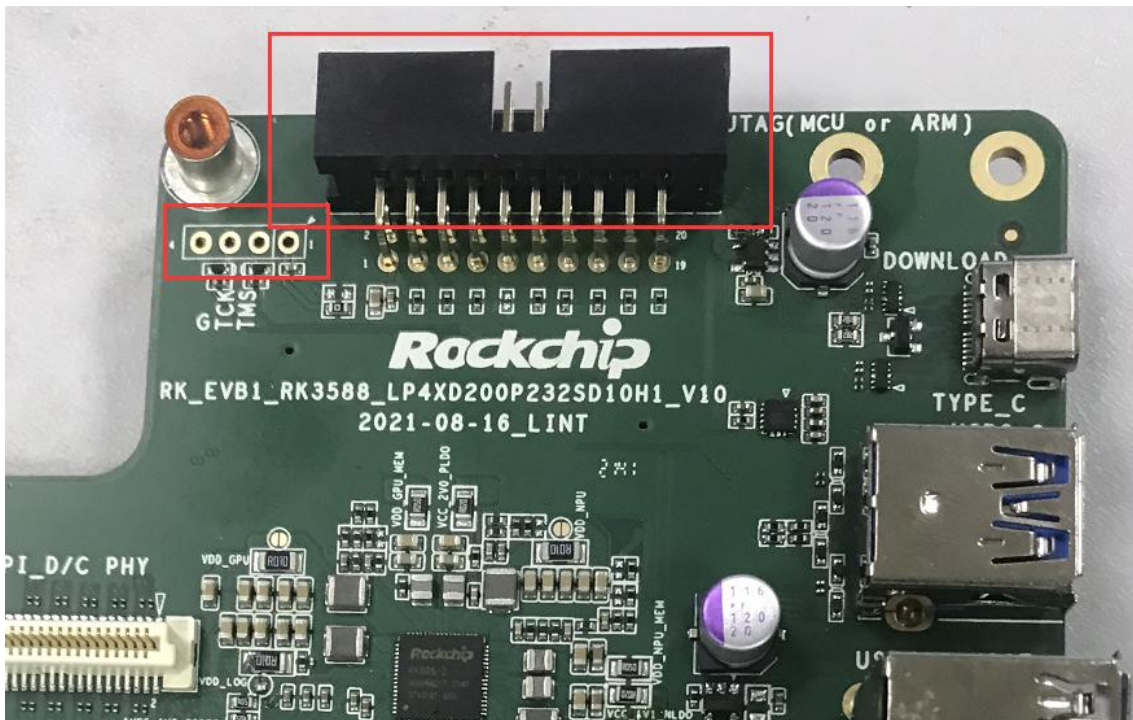

Figure 3-14JTAGSocket

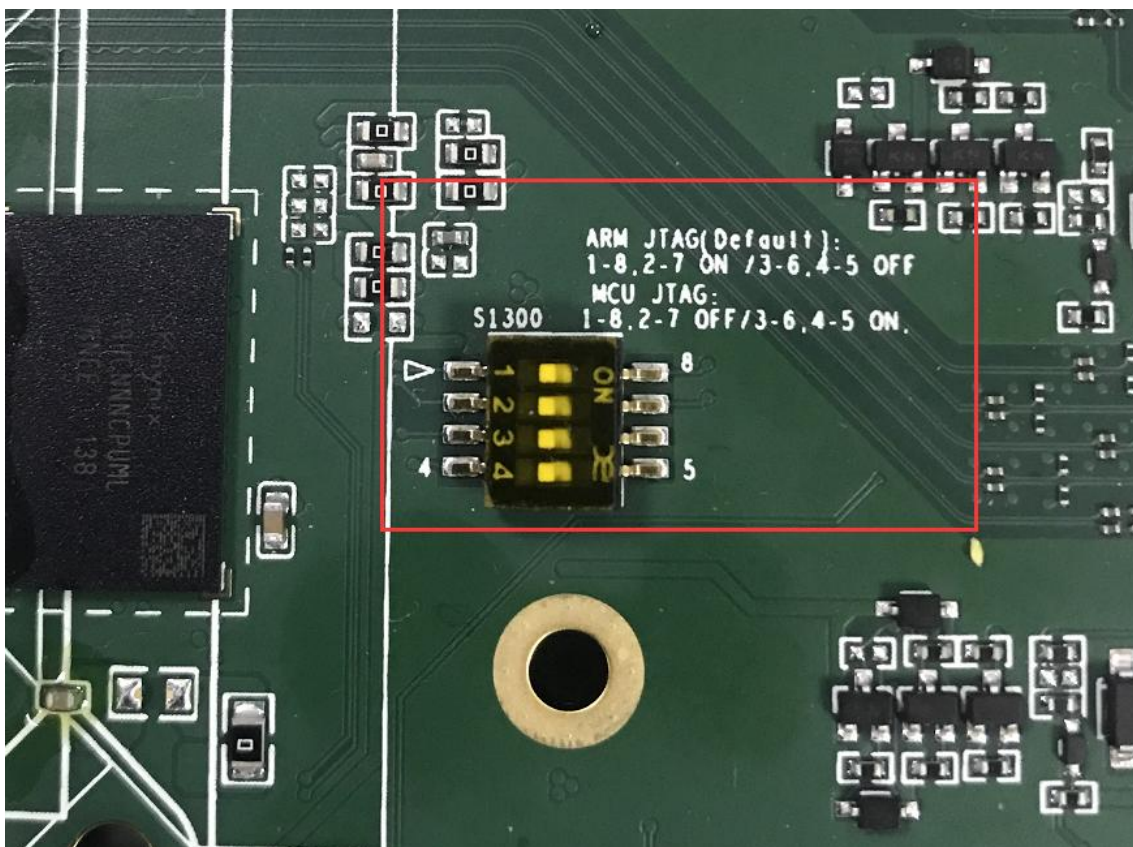

Figure 3-15DIP Switch

3.13 MIPI D/CPHY Input Interface

The MIPI D/CPHY input interface adopts a vertical 80pin socket (61082-081402LF, see section 2.4 for specifications) with a pitch of 0.8mm, and supports dual MIPI D/CPHY interface input. It can support two-way 4Lane DPHY module input or two-way 3Lane CPHY module input. MIPI DPHY/CPHY supports up to 4.5Gbps/Lane and 5.7Gbps/Trio respectively. The socket model for this 80pin socket is 61083-081402LF. Please refer to Chapter 2.4 for the package size specification. Expansion boards can be made as required.

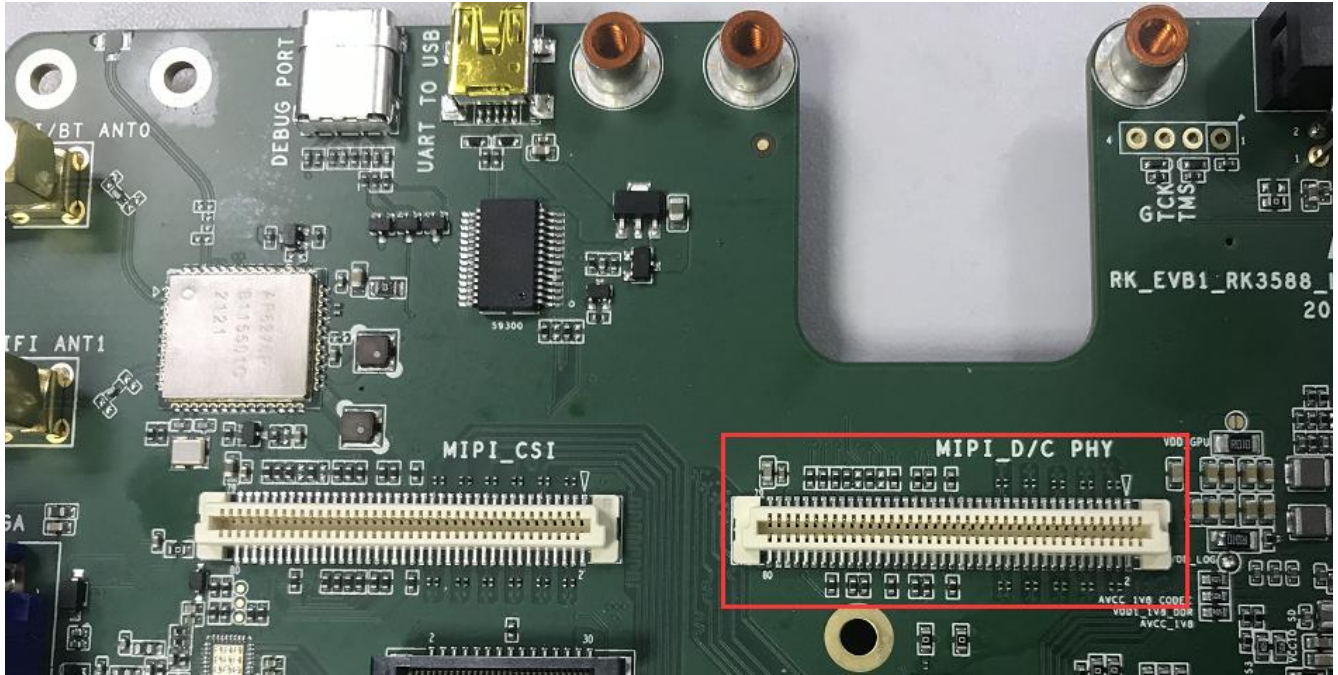

Figure 3-16MIPI D/CPHY RXInput Interface

The MIPID/CPHY_RX interface signal sequence is as follows:

Table 3-1MIPID/CPHY_RX Signal Definition Table

Pin	DPHY(single)	DPHY(dual)	CPHY (single)	CPHY (dual)	Pin
1	GND	GND	GND	GND	2
3	MIPI_DPHY0_RX_D0N	MIPI_DPHY1_RX_D0N	MIPI_CPHY0_RX_TRIO0_A	MIPI_CPHY1_RX_TRIO0_A	4
5	MIPI_DPHY0_RX_D0P	MIPI_DPHY1_RX_D0P	MIPI_CPHY0_RX_TRIO0_B	MIPI_CPHY1_RX_TRIO0_B	6
7	GND	GND	GND	GND	8
9	MIPI_DPHY0_RX_D1N	MIPI_DPHY1_RX_D1N	MIPI_CPHY0_RX_TRIO0_C	MIPI_CPHY1_RX_TRIO0_C	10
11	MIPI_DPHY0_RX_D1P	MIPI_DPHY1_RX_D1P	MIPI_CPHY0_RX_TRIO1_A	MIPI_CPHY1_RX_TRIO1_A	12
13	GND	GND	GND	GND	14
15	MIPI_DPHY0_RX_CLKN	MIPI_DPHY1_RX_CLKN	MIPI_CPHY0_RX_TRIO1_B	MIPI_CPHY1_RX_TRIO1_B	16
17	MIPI_DPHY0_RX_CLKP	MIPI_DPHY1_RX_CLKP	MIPI_CPHY0_RX_TRIO1_C	MIPI_CPHY1_RX_TRIO1_C	18
19	GND	GND	GND	GND	20
21	MIPI_DPHY0_RX_D2N	MIPI_DPHY1_RX_D2N	MIPI_CPHY0_RX_TRIO2_A	MIPI_CPHY1_RX_TRIO2_A	22
23	MIPI_DPHY0_RX_D2P	MIPI_DPHY1_RX_D2P	MIPI_CPHY0_RX_TRIO2_B	MIPI_CPHY1_RX_TRIO2_B	24
25	GND	GND	GND	GND	26
27	MIPI_DPHY0_RX_D3N	MIPI_DPHY1_RX_D3N	MIPI_CPHY0_RX_TRIO2_C	MIPI_CPHY1_RX_TRIO2_C	28

Pin	DPHY(single)	DPHY(dual)	CPHY (single)	CPHY (dual)	Pin
29	MIPI_DPHY0_RX_D3P	MIPI_DPHY1_RX_D3P	NO_USE	NO_USE	30
31	GND	GND	GND	GND	32
33	NC	NC	NC	NC	34
35	NC	NC	NC	NC	36
37	GND	GND	GND	GND	38
39	MIPI_CAM1_CLKOUT	MIPI_CAM2_CLKOUT	MIPI_CAM1_CLKOUT	MIPI_CAM2_CLKOUT	40
41	NC	NC	NC	NC	42
43	GND	GND	GND	GND	44
45	I2C5_SDA_M0_MIPI	I2C5_SDA_M0_MIPI	I2C5_SDA_M0_MIPI	I2C5_SDA_M0_MIPI	46
47	I2C5_SCL_M0_MIPI	I2C5_SCL_M0_MIPI	I2C5_SCL_M0_MIPI	I2C5_SCL_M0_MIPI	48
49	NC	NC	NC	NC	50
51	MIPI_DCPHY0_RX_PDN_H	MIPI_DCPHY1_RX_PDN_H	MIPI_DCPHY0_RX_PDN_H	MIPI_DCPHY1_RX_PDN_H	52
53	NC	NC	NC	NC	54
55	NC	NC	NC	NC	56
57	MIPI_DPHY_FSYNC	MIPI_DPHY_FSYNC	MIPI_DPHY_FSYNC	MIPI_DPHY_FSYNC	58
59	MIPI_DPHY_HSYNC	MIPI_DPHY_HSYNC	MIPI_DPHY_HSYNC	MIPI_DPHY_HSYNC	60
61	VCC_1V8_S3	VCC_3V3_S3	VCC_1V8_S3	VCC_3V3_S3	62
63	NC	NC	NC	NC	64
65	MIPI_DCPHY0_PWREN0_H	MIPI_DCPHY0_PWREN1_H	MIPI_DCPHY0_PWREN0_H	MIPI_DCPHY0_PWREN1_H	66
67	IRC_AIN	NC	IRC_AIN	NC	68
69	IRC_BIN	NC	IRC_BIN	NC	70
71	NC	NC	NC	NC	72
73	NC	NC	NC	NC	74
75	GND	GND	GND	GND	76
77	VCC5V0_SYS	GND	VCC5V0_SYS	GND	78
79	VCC5V0_SYS	VCC12V_DCIN	VCC5V0_SYS	VCC12V_DCIN	80

3.14 MIPI DPHY Input Interface

The MIPI DPHY input interface adopts a vertical 80pin socket with a pitch of 0.8mm (61082-081402LF, see section 2.4 for specifications). It can support two-way 4Lane MIPI DPHY module inputs or four 2Lane MIPI DPHY signal inputs. MIPI DPHY supports up to 2.5Gbps/Lane respectively. Together with MIPI D/CPHY, it can form a maximum of 6 module inputs. The socket model for this 80pin socket is 61083-081402LF. Please refer to Chapter 2.4 for the package size specification.

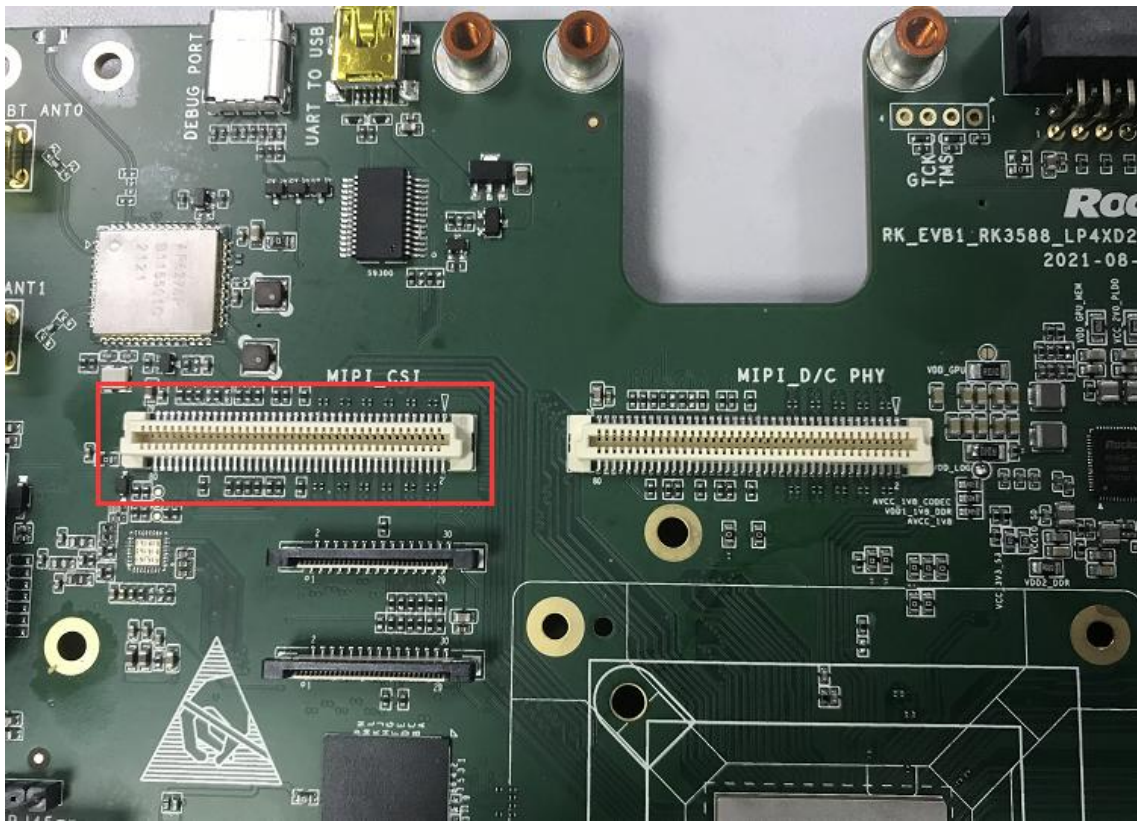

Figure 3-17MIPI DPHY Video Input Interface

Table 3-2MIPI DPHY_RX Signal Definition Table

Pin	DPHY(single)	DPHY (dual)	Pin
1	GND	GND	2
3	MIPI_CSI0_RX_D0N	MIPI_CSI1_RX_D0N	4
5	MIPI_CSI0_RX_D0P	MIPI_CSI1_RX_D0P	6
7	GND	GND	8
9	MIPI_CSI0_RX_D1N	MIPI_CSI1_RX_D1N	10
11	MIPI_CSI0_RX_D1P	MIPI_CSI1_RX_D1P	12
13	GND	GND	14
15	MIPI_CSI0_RX_CLK0N	MIPI_CSI1_RX_CLK0N	16
17	MIPI_CSI0_RX_CLK0P	MIPI_CSI1_RX_CLK0P	18
19	GND	GND	20
21	MIPI_CSI0_RX_D2N	MIPI_CSI1_RX_D2N	22
23	MIPI_CSI0_RX_D2P	MIPI_CSI1_RX_D2P	24
25	GND	GND	26
27	MIPI_CSI0_RX_D3N	MIPI_CSI1_RX_D3N	28
29	MIPI_CSI0_RX_D3P	MIPI_CSI1_RX_D3P	30
31	GND	GND	32
33	MIPI_CSI0_RX_CLK1N	MIPI_CSI1_RX_CLK1N	34

Pin	DPHY(single)	DPHY (dual)	Pin
35	MIPI_CSI0_RX_CLK1P	MIPI_CSI1_RX_CLK1P	36
37	GND	GND	38
39	MIPI_CAM3_CLKOUT	MIPI_CAM4_CLKOUT	40
41	NC	NC	42
43	GND	GND	44
45	I2C3_SDA_M0_MIPI	I2C4_SDA_M3_MIPI	46
47	I2C3_SCL_M0_MIPI	I2C4_SCL_M3_MIPI	48
49	NC	NC	50
51	MIPI_CSI0_PDN0_H	MIPI_CSI1_PDN0_H	52
53	NC	NC	54
55	MIPI_CSI0_PDN1_H	MIPI_CSI1_PDN1_H	56
57	MIPI_DPHY_FSYNC	MIPI_DPHY_FSYNC	58
59	MIPI_DPHY_HSYNC	MIPI_DPHY_HSYNC	60
61	VCC_1V8_S3	VCC_3V3_S3	62
63	NC	NC	64
65	MIPICSI0_PWREN_H	MIPICSI1_PWREN_H	66
67	IRC_AIN	NC	68
69	IRC_BIN	NC	70
71	NC	NC	72
73	NC	NC	74
75	GND	GND	76
77	VCC5V0_SYS	GND	78
79	VCC5V0_SYS	VCC12V_DCIN	80

3.15 TYPECInterface

The development board supports a complete TYPEC interface and supports the following functions:

- TYPEC0_USB20_OTG in this interface can be used to download firmware
- Support TYPEC function
- Support DP1.4 output

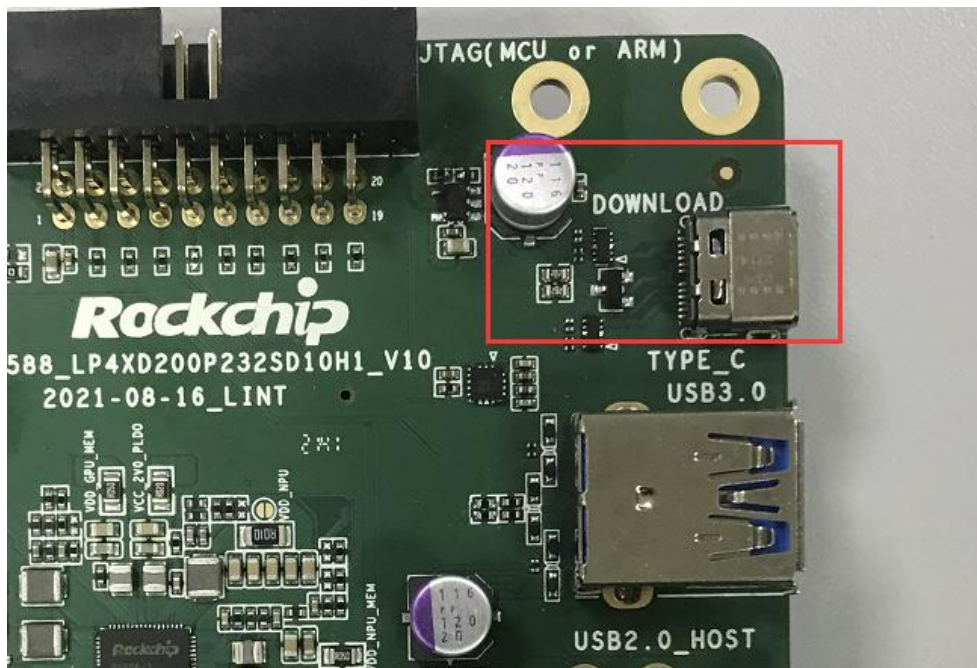

Figure 3-18TYPECEC Interface

3.16 USB3.0Interface

The development board supports one USB3.0 OTG interface; the interface is a standard A port, which is convenient for developers to access USB3.0 U disk and other USB3.0 devices.

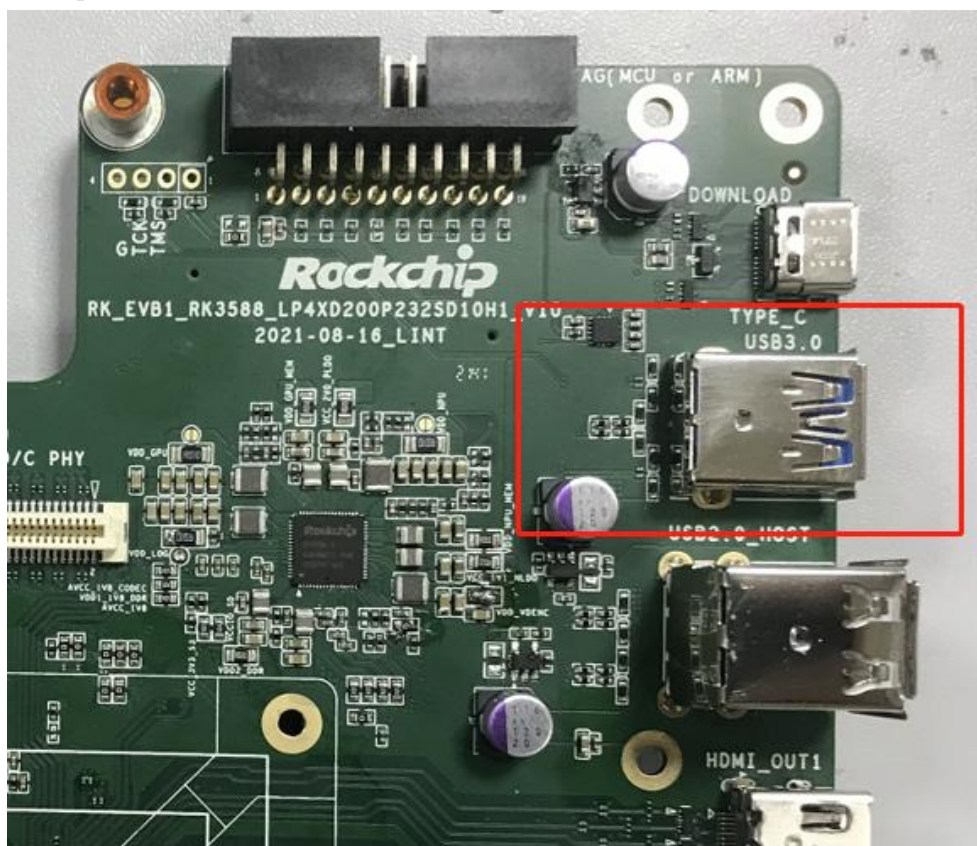

Figure 3-19USB3.0 OTGInterface

3.17 USB2.0 HostInterface

The development board supports two channels of USB2.0; it is integrated on a double-layer USB device and can support the connection of USB devices, such as mouse, U disk, and Bluetooth.

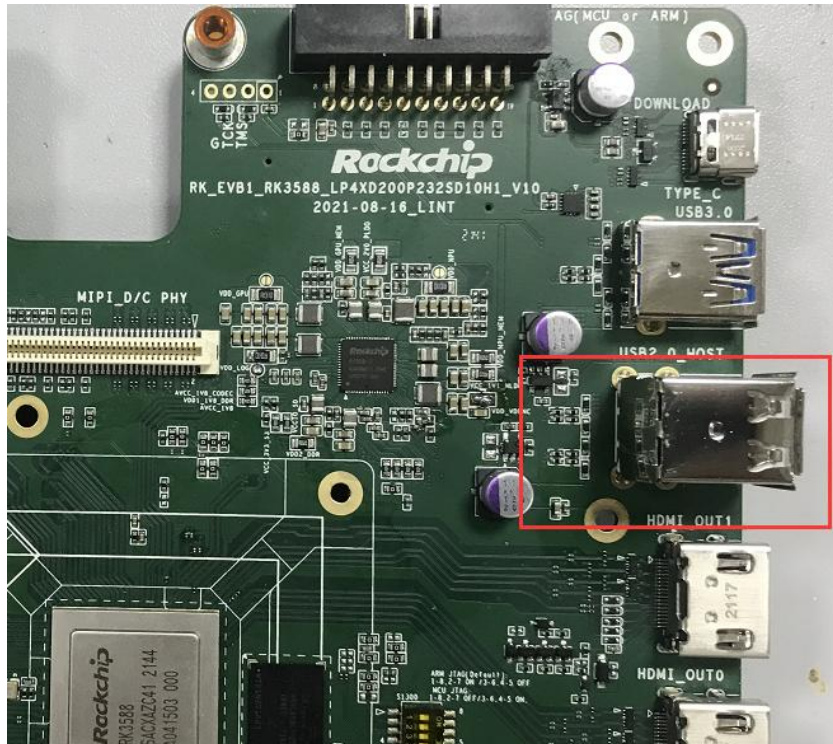

Figure 3-20USB2.0 HostInterface

3.18 HDMIOutput Interface

The development board supports two HDMI standard A output interfaces, up to HDMI2.1, and up to 8K@60fps video output.

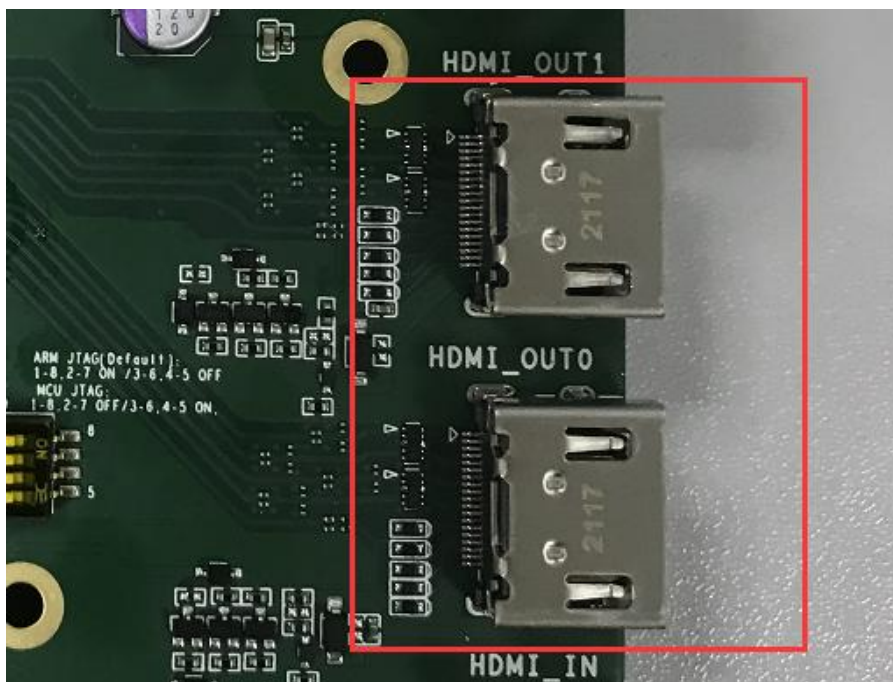

Figure 3-21HDMI TXInterface

3.19 HDMI Input Interface

The development board supports one HDMI input interface, up to HDMI2.0 video input.

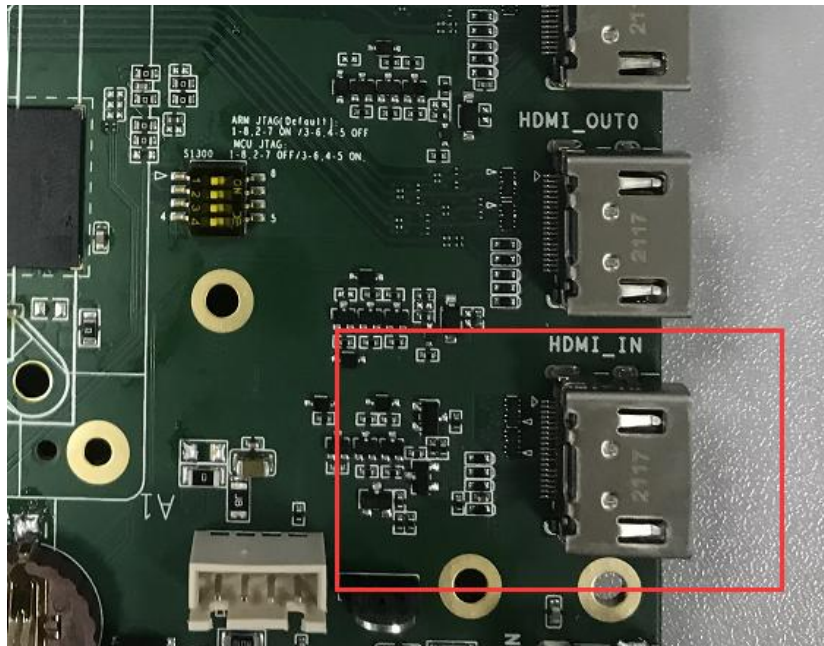

Figure 3-22HDMI RXInterface

3.20 Fan Power Connector

The development board reserves a fan interface, supports 12V/5V fans, and supports adjustable speed. The development board equip with a 12V fan by default.

The interface line sequence from left to right is GND, 12V, SENSOR, CONTROL.

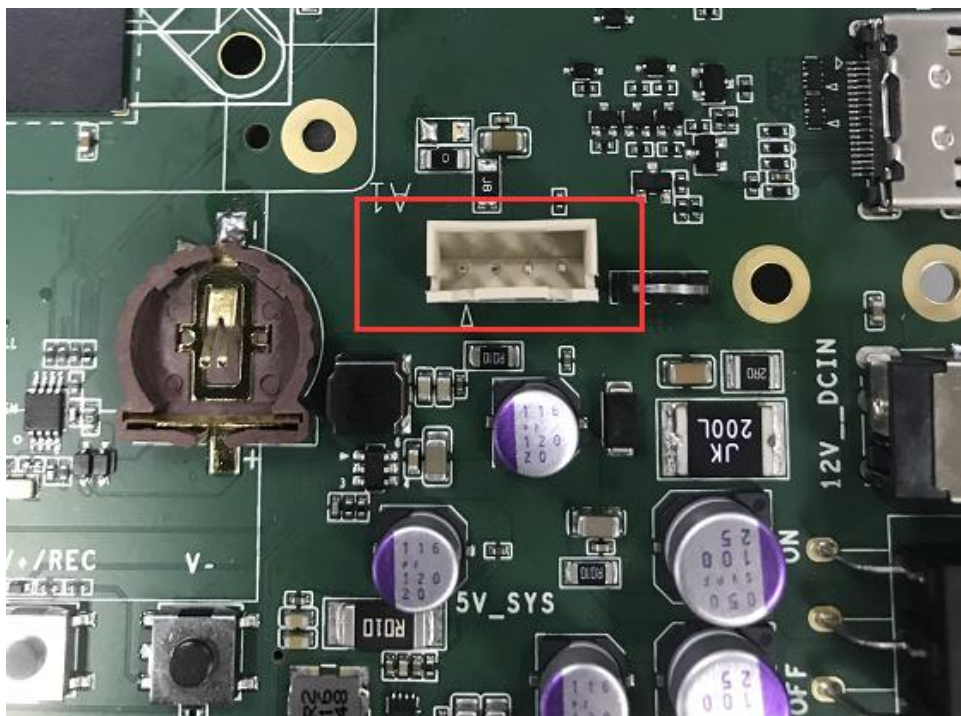

Figure 3-23Fan Power Interface

3.21 Sensor Module Expansion

The development board is equipped with an IMX415 module, which can support up to 800W pixels.

- Support automatic white balance, 3D noise reduction, HDR;
- Support RAW10/RAW12 data output;
- Integrated IRCUT switching circuit, which can control the sensor module day and night mode;
- One set of 24pin MIPI interface is reserved on the module, which can be extended to stereo vision application as needed.

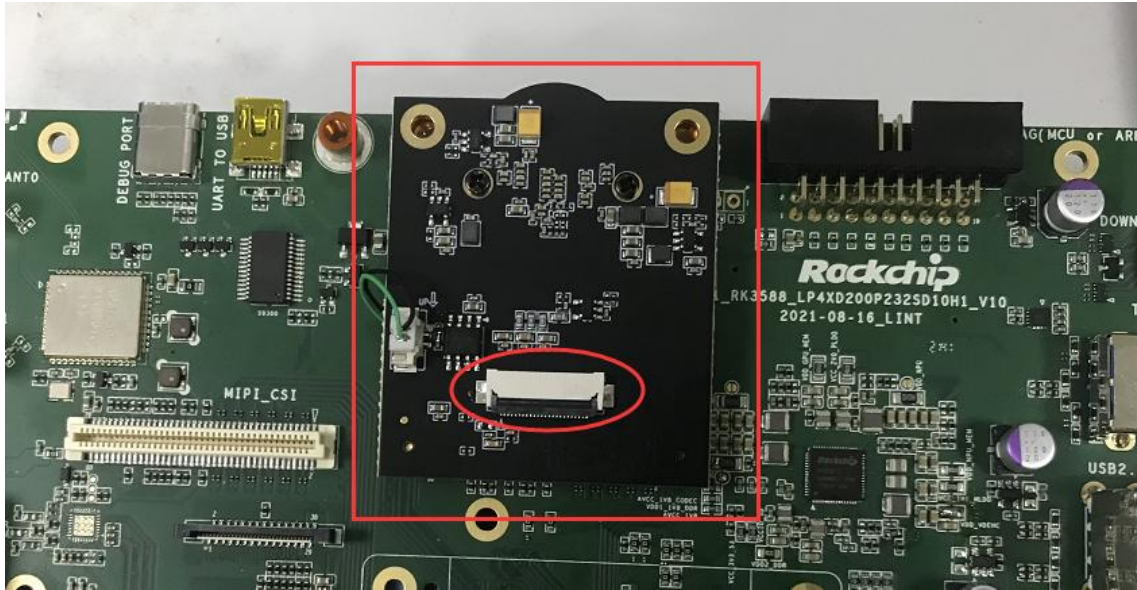

Figure 3-24IMX415 Module Board

The IMX415 module expansion interface signal sequence is as follows:

Table 3-3IMX415 Module Expansion Interface Signal Definition Table

Pin	DPHY
1	GND
2	GND
3	NC
4	MIPI_DCPHY1_RX_RST_L
5	I2C5_SDA_M0_MIPI
6	I2C5_SCL_M0_MIPI
7	GND
8	GND
9	MIPI_DPHY1_RX_D0N
10	MIPI_DPHY1_RX_D0P
11	MIPI_DPHY1_RX_D1N
12	MIPI_DPHY1_RX_D1P
13	MIPI_DPHY1_RX_D2N
14	MIPI_DPHY1_RX_D2P

Pin	DPHY
15	MIPI_DPHY1_RX_D3N
16	MIPI_DPHY1_RX_D3P
17	GND
18	MIPI_DPHY1_RX_CLKN
19	MIPI_DPHY1_RX_CLKP
20	GND
21	MIPI_CAM2_CLKOUT
22	VCC_3V3_O
23	VCC_3V3_D
24	VCC_3V3_A

3.22 Speaker Interface

The development board reserves 2 speaker ports.

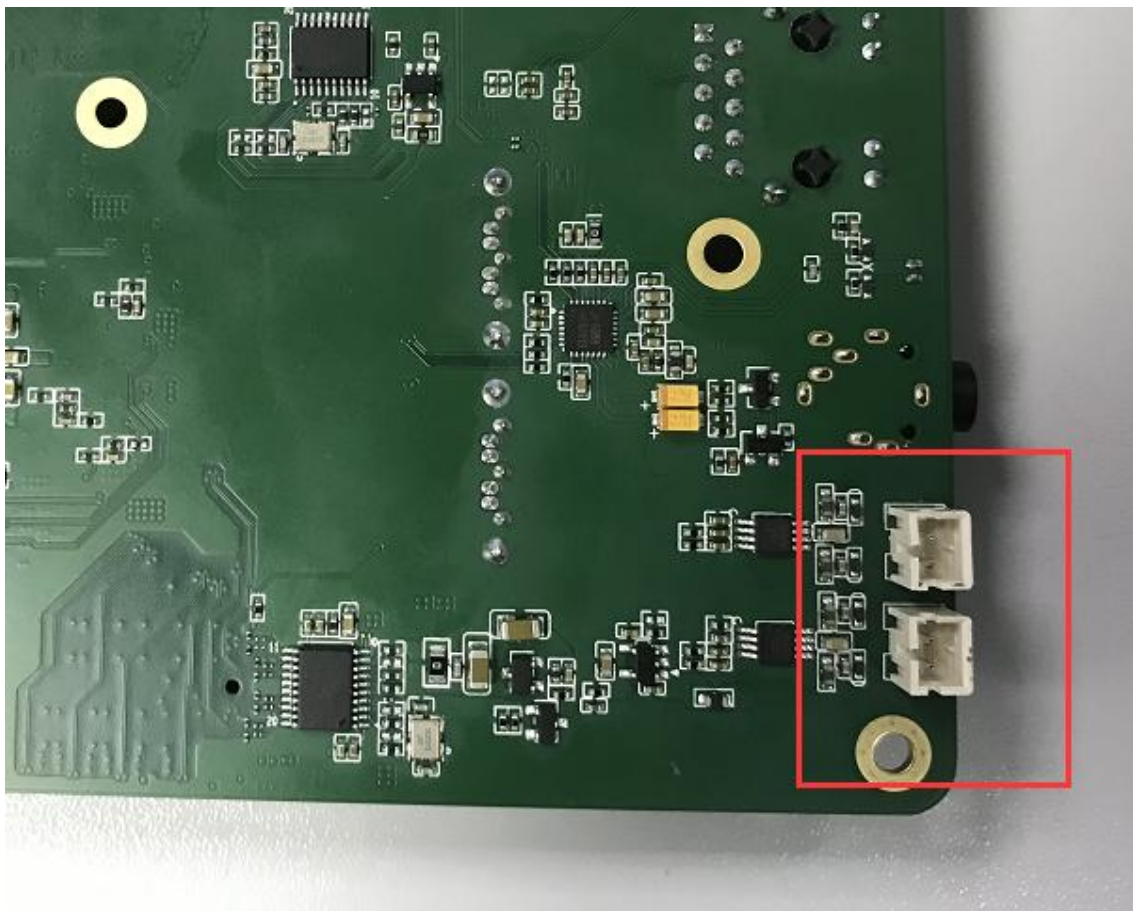

Figure 3-25 SPK Socket

4 Precautions

RK3588 EVB is suitable for laboratory or engineering environment, please read the following precautions before operation:

- Under no circumstances can the screen interface and expansion board be hot-swapped.
- Before unpacking and installing the development board, take necessary anti-static measures to avoid electrostatic discharge (ESD) damage to the development board hardware.
- When holding the development board, please hold the edge of the development board, and do not touch the exposed metal parts of the development board, so as to avoid damage to the components of the development board caused by static electricity.
- Please place the development board on a dry surface to keep them away from heat sources, electromagnetic interference sources and radiation sources, electromagnetic radiation sensitive equipment (such as medical equipment), etc.